

MATERIAL:

PART NO.	A 44200-085	REV	ECO	DATE	APP
		A	103653	07-29-17	TLM

SHELL:

ALUMINUM 6061-T6,
NICKEL PLATE (500
MICROINCHES MINIMUM)
PER SAE-AMS-2404

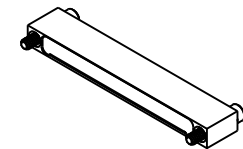

ACTUAL SIZE

HARDWARE:

303 STAINLESS STEEL PER
ASTM 582

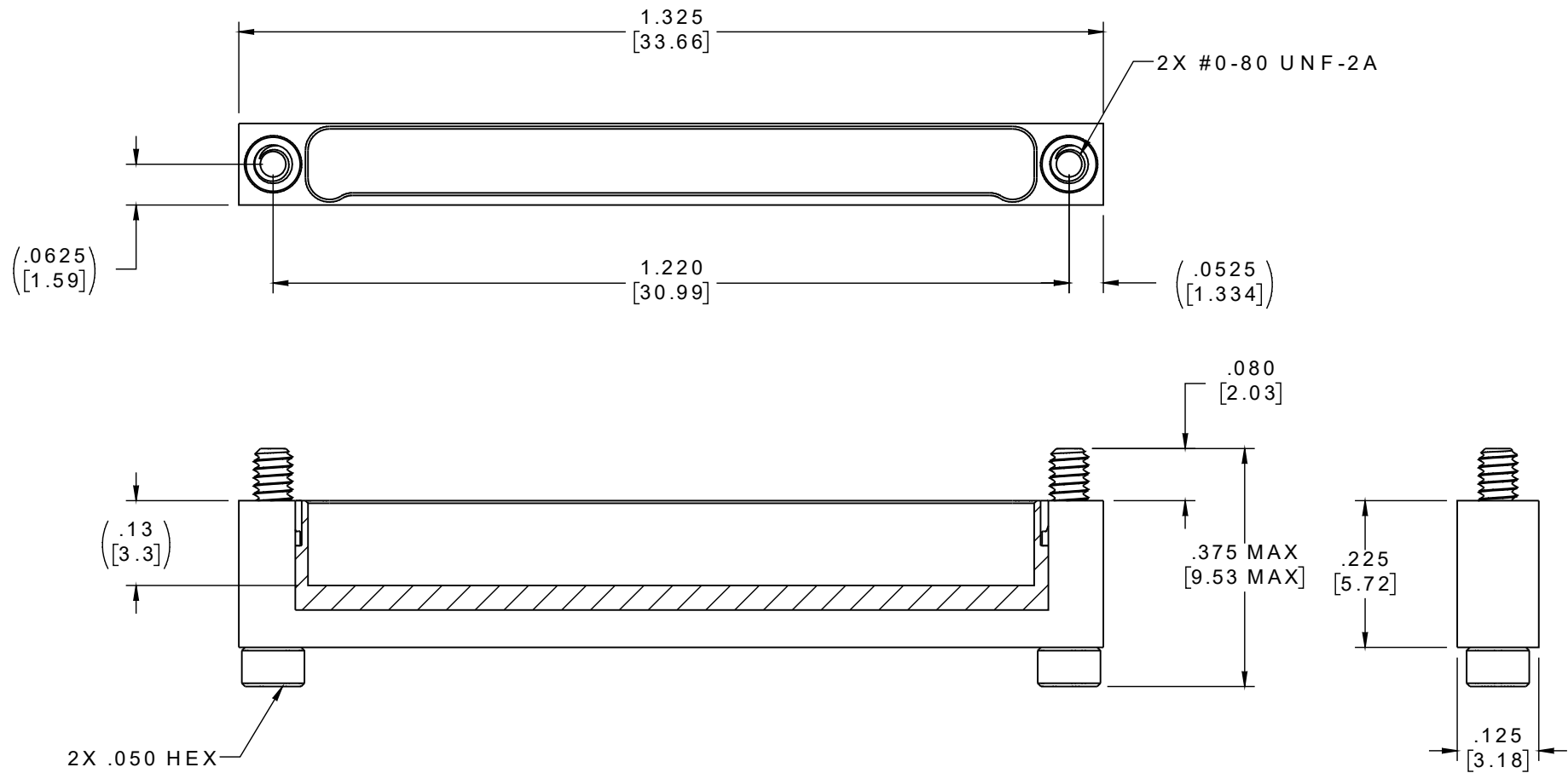

NOTE:

DIMENSIONS IN [] ARE IN MILLIMETERS UNLESS OTHERWISE NOTED AND ARE FOR REFERENCE ONLY

THIRD ANGLE UNLESS OTHERWISE NOTED DIMENSIONS IN INCHES 2 PL DEC ± .01 3 PL DEC ± .005 4 PL DEC ± .0005 ANGLES ± 1°	THIS DRAWING CONTAINS CONFIDENTIAL AND PROPRIETARY INFORMATION WHICH IS THE PROPERTY OF OMNETICS CONNECTOR CORP. THIS DOCUMENT MAY NOT, IN WHOLE OR IN PART, BE DUPLICATED, OR DISCLOSED FOR ANY PURPOSE, WITHOUT WRITTEN PERMISSION FROM OMNETICS CONNECTOR CORP.		OMNETICS CONNECTOR CORPORATION 7260 COMMERCE CIRCLE EAST MINNEAPOLIS, MN 55432 WWW.OMNETICS.COM	CAGE CODE 61873		
	DFTM. TLM	DATE 07-10-17		TITLE: DUST COVER MALE Bi-Lobe® (85) POSITION	DWG NO. A44200-085	
	CHK'D.	DATE			SHEET 1 OF 1	REV A
	APP'D.	DATE			SCALE: 4:1	