

MATERIAL:

PART NO.	A 44200-065	REV	ECO	DATE	APP
		A	103653	07-29-17	TLM

SHELL:

ALUMINUM 6061-T6,
NICKEL PLATE (500
MICROINCHES MINIMUM)
PER SAE-AMS-2404

HARDWARE:

303 STAINLESS STEEL PER
ASTM 582

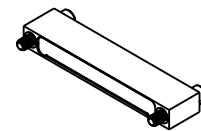

ACTUAL SIZE

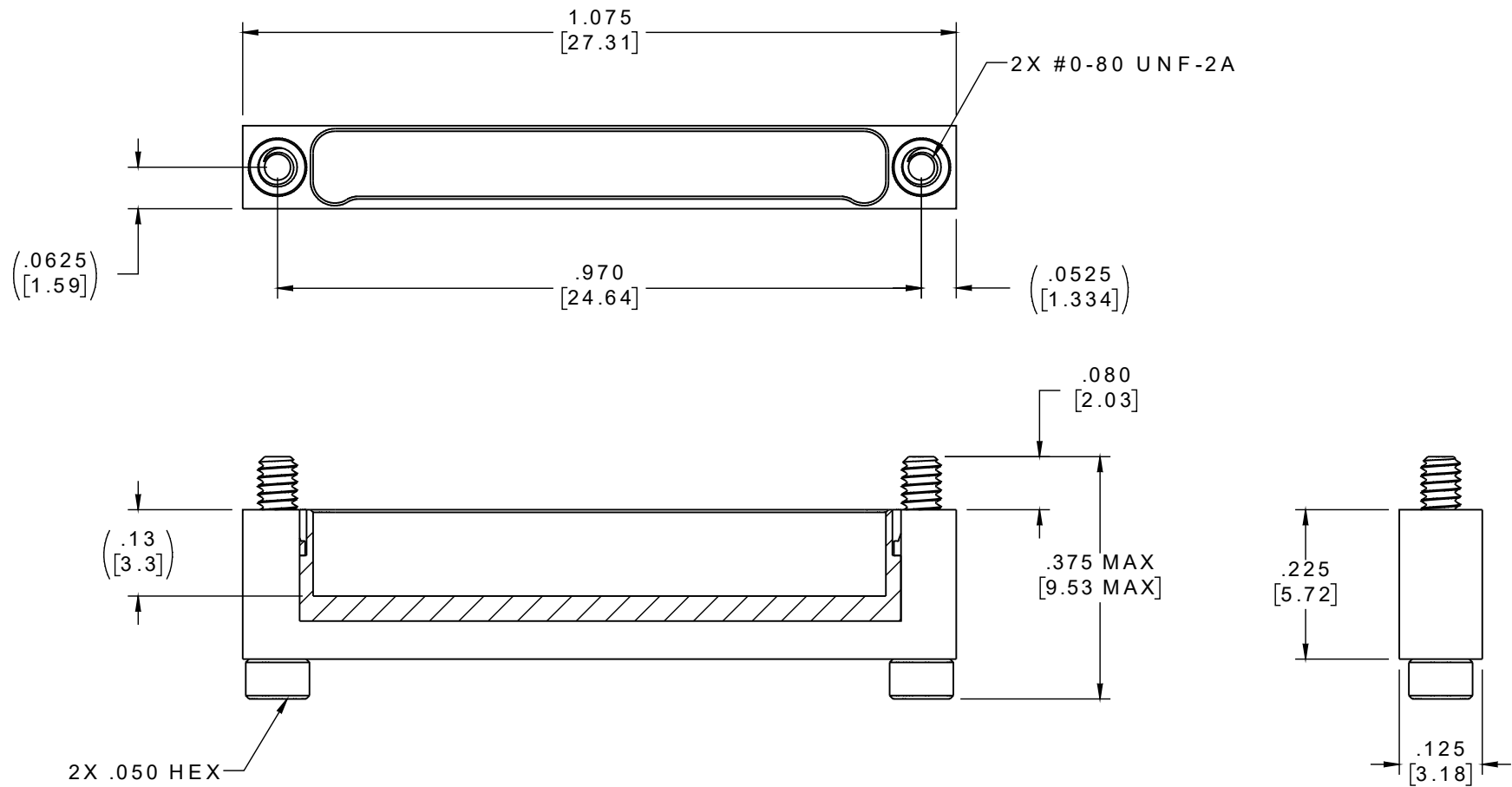

NOTE:

DIMENSIONS IN [] ARE IN MILLIMETERS UNLESS OTHERWISE NOTED AND ARE FOR REFERENCE ONLY

ASDW	THIRD ANGLE
	-TOLERANCES-
	UNLESS OTHERWISE NOTED
	DIMENSIONS IN INCHES
	2 PL DEC ± .01
	3 PL DEC ± .005
	4 PL DEC ± .0005
	ANGLES ± 1°

THIS DRAWING CONTAINS CONFIDENTIAL AND PROPRIETARY INFORMATION WHICH IS THE PROPERTY OF OMNETICS CONNECTOR CORP. THIS DOCUMENT MAY NOT, IN WHOLE OR IN PART, BE DUPLICATED, OR DISCLOSED FOR ANY PURPOSE, WITHOUT WRITTEN PERMISSION FROM OMNETICS CONNECTOR CORP.			
DFTM. TLM	DATE	TITLE:	
	07-10-17	DUST COVER	
CHK'D.	DATE	MALE Bi-Lobe®	
		(65) POSITION	
APP'D.	DATE		

OMNETICS
CONNECTOR CORPORATION
7260 COMMERCE CIRCLE EAST
MINNEAPOLIS, MN 55432
WWW.OMNETICS.COM

CAGE CODE 61873	
DWG NO. A44200-065	
SHEET 1 OF 1	REV A
SCALE: 4:1	