

PART NO.	A44200-031	REV	ECO	DATE	APP
		A	103653	07-29-17	TLM

**MATERIAL:**

**SHELL:**

ALUMINUM 6061-T6,  
NICKEL PLATE (500  
MICROINCHES MINIMUM)  
PER SAE-AMS-2404

**HARDWARE:**

303 STAINLESS STEEL PER  
ASTM 582

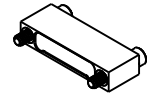

ACTUAL SIZE

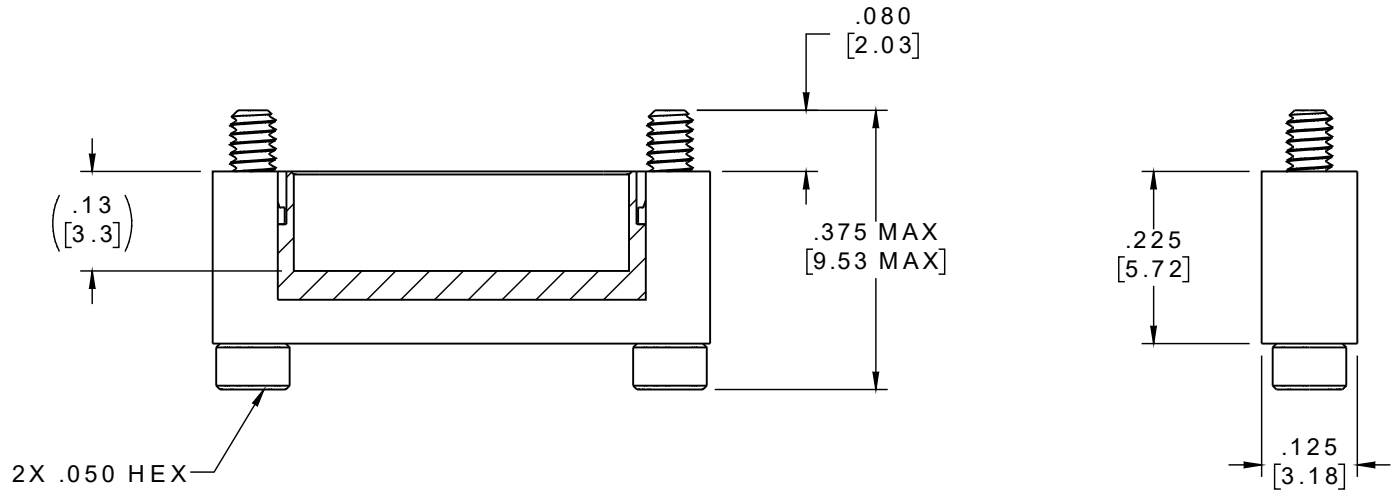
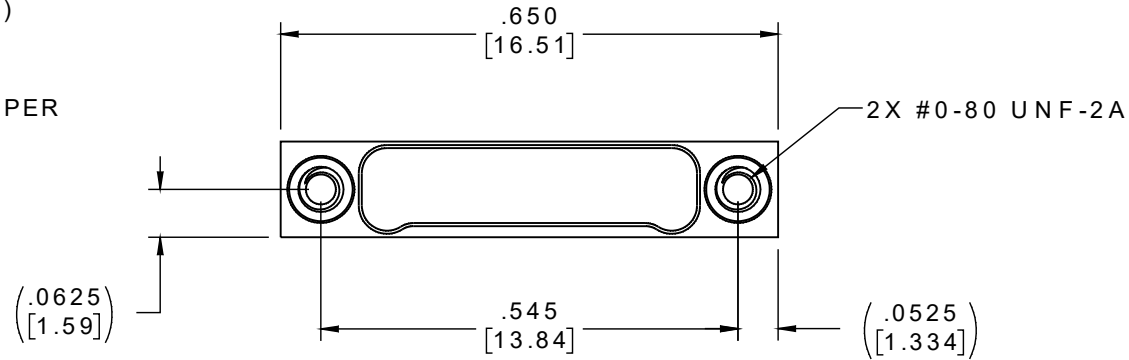

**NOTE:**

DIMENSIONS IN [ ] ARE IN  
MILLIMETERS UNLESS  
OTHERWISE NOTED AND ARE  
FOR REFERENCE ONLY

MATERIALS	THIRD ANGLE	THIS DRAWING CONTAINS CONFIDENTIAL AND PROPRIETARY INFORMATION WHICH IS THE PROPERTY OF OMNETICS CONNECTOR CORP. THIS DOCUMENT MAY NOT, IN WHOLE OR IN PART, BE DUPLICATED, OR DISCLOSED FOR ANY PURPOSE, WITHOUT WRITTEN PERMISSION FROM OMNETICS CONNECTOR CORP.		<b>OMNETICS</b> CONNECTOR CORPORATION 7260 COMMERCE CIRCLE EAST MINNEAPOLIS, MN 55432 WWW.OMNETICS.COM	CAGE CODE 61873		
	-TOLERANCES- UNLESS OTHERWISE NOTED	DFTM. TLM	DATE 07-10-17		TITLE: DUST COVER MALE Bi-Lobe® (31) POSITION	DWG NO. A44200-031	
	DIMENSIONS IN INCHES	CHK'D.	DATE			SHEET 1 OF 1	
	2 PL DEC ± .01 3 PL DEC ± .005 4 PL DEC ± .0005 ANGLES ± 1°	APP'D.	DATE			REV A	SCALE: 4:1