

PART NO.	A98118-009	REV	ECO	DATE	APP
		A	101818	08-11-15	TLM

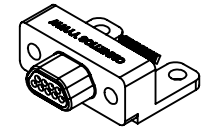
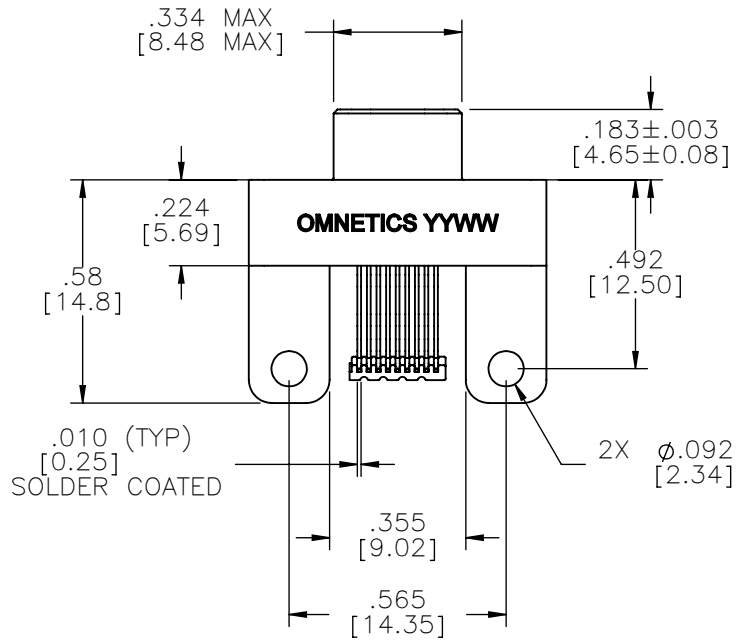
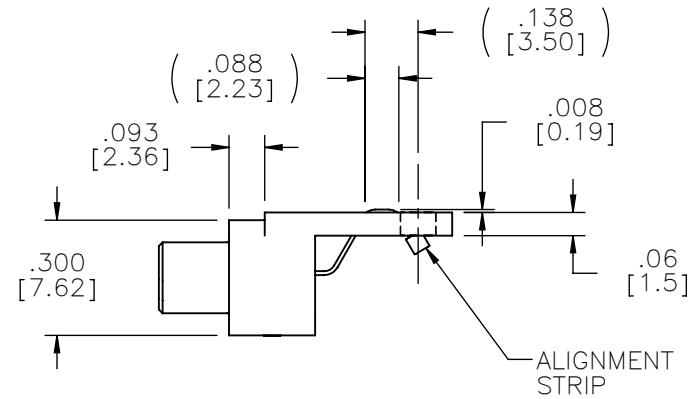
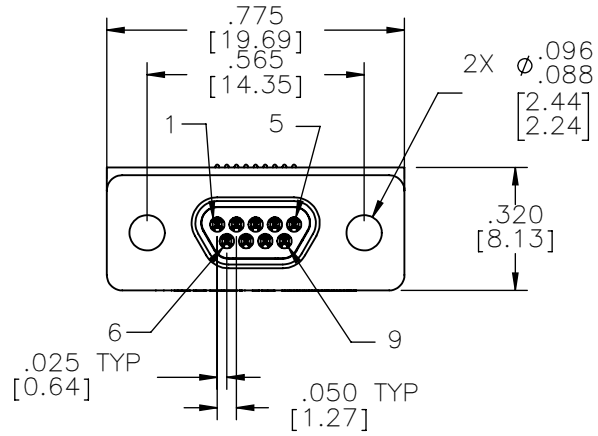

ACTUAL SIZE

NOTE:

DIMENSIONS IN [] ARE IN MILLIMETERS UNLESS OTHERWISE NOTED AND ARE FOR REFERENCE ONLY

MMP	THIRD ANGLE
	-TOLERANCES-
MCS	UNLESS OTHERWISE NOTED
	DIMENSIONS IN INCHES
	2 PL DEC± .01
	3 PL DEC± .005
	4 PL DEC± .0005
	ANGLES ± 1°

THIS DRAWING CONTAINS CONFIDENTIAL AND PROPRIETARY INFORMATION WHICH IS THE PROPERTY OF OMNETICS CONNECTOR CORP. THIS DOCUMENT MAY NOT, IN WHOLE OR IN PART, BE DUPLICATED, OR DISCLOSED FOR ANY PURPOSE, WITHOUT WRITTEN PERMISSION FROM OMNETICS CONNECTOR CORP.	
DFTM. TLM	DATE 07-27-15
CHK'D.	DATE
APP'D.	DATE

TITLE:
 (9) PIN MALE
 HORIZONTAL SURFACE
 MOUNT MICRO-D

OMNETICS
 CONNECTOR CORPORATION
 7260 COMMERCE CIRCLE EAST
 MINNEAPOLIS, MN 55432
 WWW.OMNETICS.COM

CAGE CODE 61873	
DWG NO. A98118-009	
SHEET 1 OF 2	REV A
SCALE: 2:1	

PART NO.	A98118-009	REV	ECO	DATE	APP
		A	101818	08-11-15	TLM

MATERIALS

HOUSING:

ALUMINUM 6061-T6, NICKEL
PLATE PER SAE-AMS-2404

INSULATOR & ALIGNMENT STRIP:

LIQUID CRYSTAL POLYMER (LCP)
PER ASTM D5138

CONTACT:

BERYLLIUM COPPER PER ASTM
B194, C17200, GOLD PLATED
PER ASTM B488, (HARD GOLD)
TYPE II CODE C, CLASS 1.27

TERMINATION:

SOLDER COATED WITH SN63A
PER J-STD-006 OR AMS-P-
81728

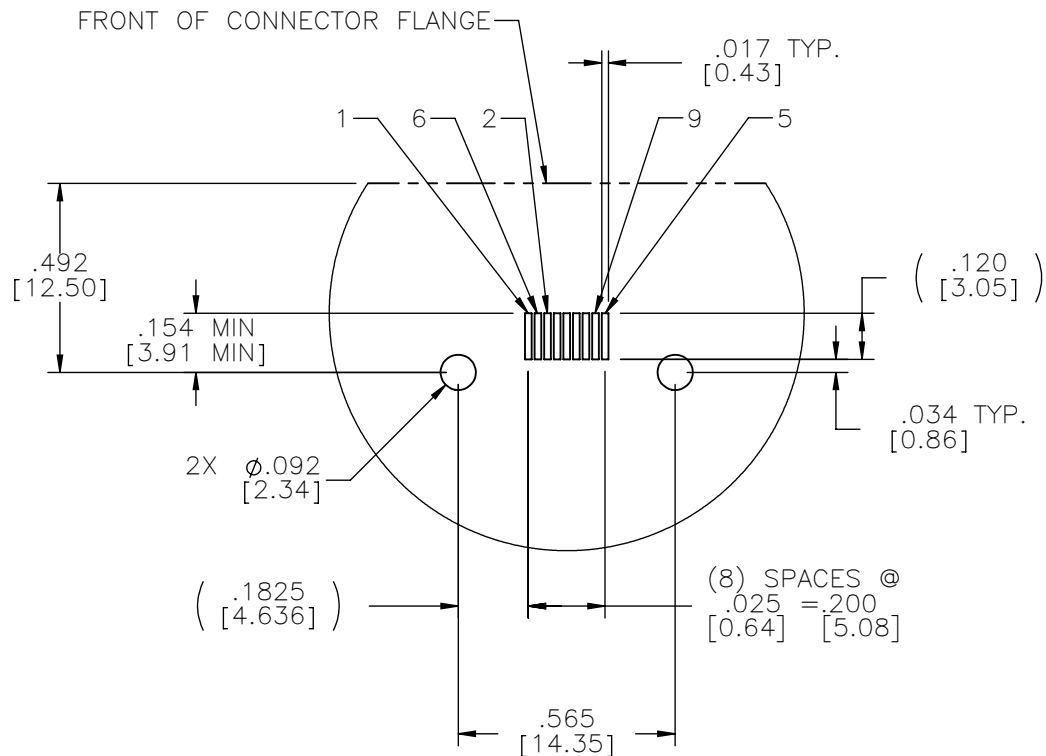

FRONT OF CONNECTOR
FLANGE

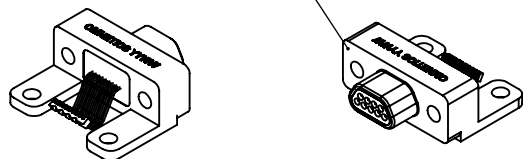

ACTUAL SIZE

SUGGESTED BOARD LAYOUT

NOTE:

DIMENSIONS IN [] ARE IN
MILLIMETERS UNLESS
OTHERWISE NOTED AND ARE
FOR REFERENCE ONLY

MGT'S CHK'D APP'D	THIRD ANGLE
	-TOLERANCES-
	UNLESS OTHERWISE NOTED
	DIMENSIONS IN INCHES
	2 PL DEC ± .01 3 PL DEC ± .005 4 PL DEC ± .0005 ANGLES ± 1°

THIS DRAWING CONTAINS CONFIDENTIAL AND PROPRIETARY INFORMATION WHICH IS THE PROPERTY OF OMNETICS CONNECTOR CORP. THIS DOCUMENT MAY NOT, IN WHOLE OR IN PART, BE DUPLICATED, OR DISCLOSED FOR ANY PURPOSE, WITHOUT WRITTEN PERMISSION FROM OMNETICS CONNECTOR CORP.

DFTM.	TLM	DATE	07-27-15
CHK'D.		DATE	
APP'D.		DATE	

TITLE:
**(9) PIN MALE
HORIZONTAL SURFACE
MOUNT MICRO-D**

OMNETICS
CONNECTOR CORPORATION
7260 COMMERCE CIRCLE EAST
MINNEAPOLIS, MN 55432
WWW.OMNETICS.COM

CAGE CODE 61873	
DWG NO. A98118-009	
SHEET 2 OF 2	REV A
SCALE: 2:1	