

PART NO.	A98083-015	REV	ECO	DATE	APP
		B	100387	03-20-14	TLM

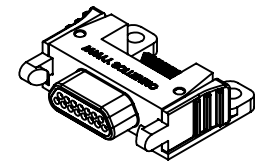
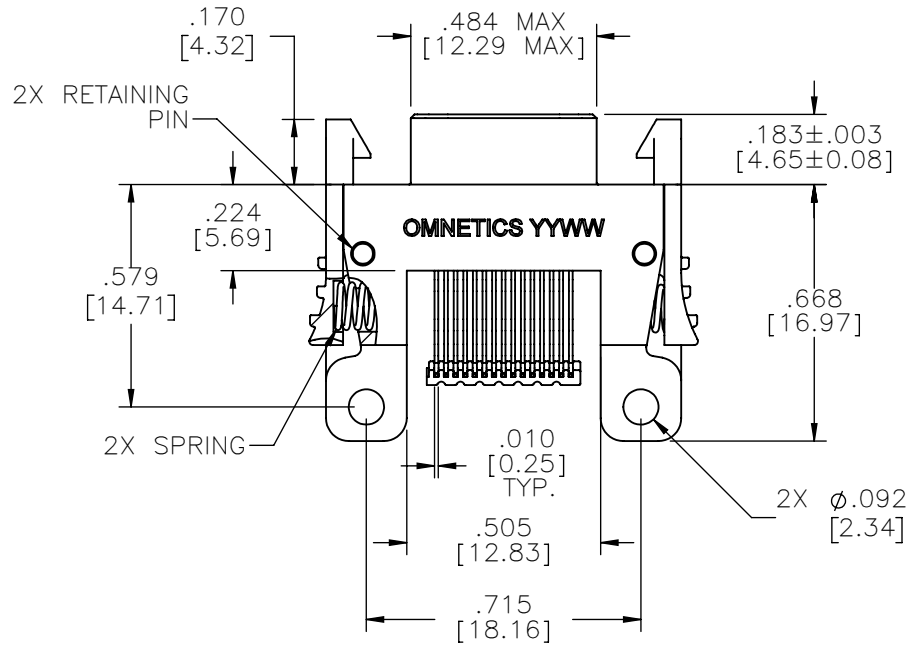
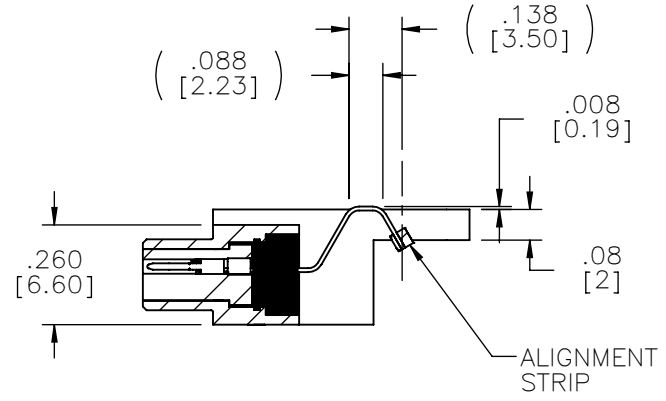
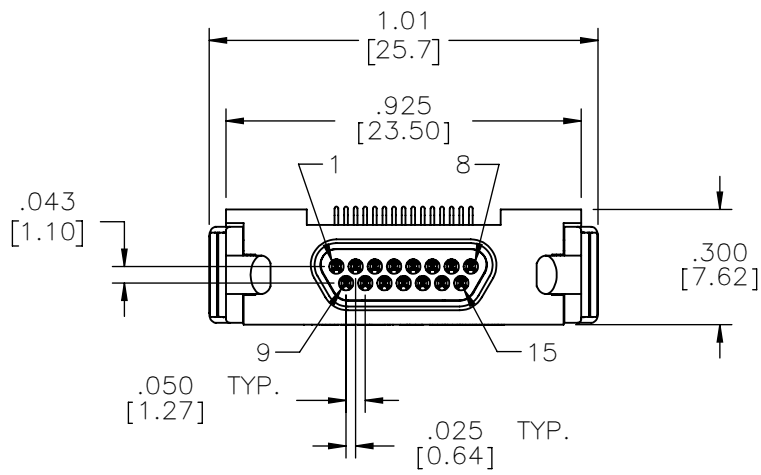

ACTUAL SIZE

NOTE:
DIMENSIONS IN [] ARE IN MILLIMETERS UNLESS OTHERWISE NOTED AND ARE FOR REFERENCE ONLY

MCTC	THIRD ANGLE
	-TOLERANCES-
	UNLESS OTHERWISE NOTED
	DIMENSIONS IN INCHES
LMDP	2 PL DEC ± .01
	3 PL DEC ± .005
	4 PL DEC ± .0005
	ANGLES ± 1°

THIS DRAWING CONTAINS CONFIDENTIAL AND PROPRIETARY INFORMATION WHICH IS THE PROPERTY OF OMNETICS CONNECTOR CORP. THIS DOCUMENT MAY NOT, IN WHOLE OR IN PART, BE DUPLICATED, OR DISCLOSED FOR ANY PURPOSE, WITHOUT WRITTEN PERMISSION FROM OMNETICS CONNECTOR CORP.	
DFTM. MJM	DATE 11-08-12
CHK'D.	DATE
APP'D.	DATE
TITLE: (15) PIN MALE HORIZONTAL SURFACE MOUNT LATCHING MICRO-D	

OMNETICS
CONNECTOR CORPORATION
7260 COMMERCE CIRCLE EAST
MINNEAPOLIS, MN 55432
WWW.OMNETICS.COM

CAGE CODE 61873	
DWG NO. A98083-015	
SHEET 1 OF 2	REV B
SCALE: 2:1	

PART NO.	A98083-015	REV	ECO	DATE	APP
		B	100387	03-20-14	TLM

MATERIALS

HOUSING:

ALUMINUM 6061-T6, NICKEL
PLATE PER SAE-AMS-2404

LATCH:

STAINLESS STEEL, NICKEL PLATE
PER SAE-AMS-2404

INSULATOR & ALIGNMENT STRIP:

LIQUID CRYSTAL POLYMER (LCP)
PER ASTM D5138

CONTACT:

BERYLLIUM COPPER PER ASTM
B194, C17200, GOLD PLATED
PER ASTM B488, (HARD GOLD)
TYPE II CODE C, CLASS 1.27

TERMINATION:

SOLDER COATED WITH SN63A
PER J-STD-006 OR AMS-P-
81728

HARDWARE:

STAINLESS STEEL, PASSIVATED
PER SAE-AMS-2700

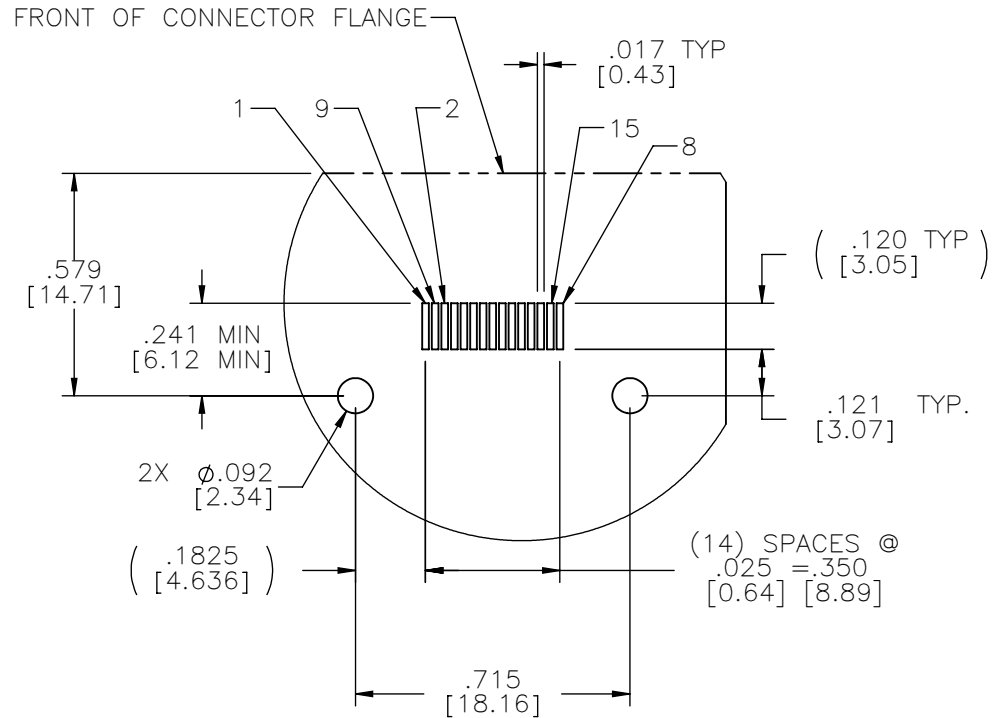

SUGGESTED BOARD LAYOUT

FRONT OF CONNECTOR FLANGE

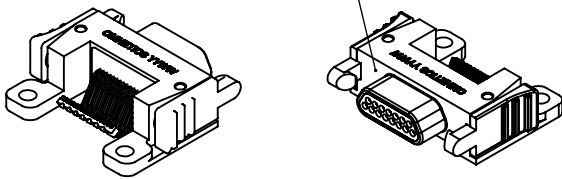

ACTUAL SIZE

THIRD ANGLE	—TOLERANCES—
	UNLESS OTHERWISE NOTED
DIMENSIONS IN INCHES	2 PL DEC ± .01
	3 PL DEC ± .005
	4 PL DEC ± .0005
	ANGLES ± 1°

THIS DRAWING CONTAINS CONFIDENTIAL AND PROPRIETARY INFORMATION WHICH IS THE PROPERTY OF OMNETICS CONNECTOR CORP. THIS DOCUMENT MAY NOT, IN WHOLE OR IN PART, BE DUPLICATED, OR DISCLOSED FOR ANY PURPOSE, WITHOUT WRITTEN PERMISSION FROM OMNETICS CONNECTOR CORP.

DFTM. JMJ	DATE
CHK'D.	DATE
APP'D.	DATE

TITLE:
(15) PIN MALE
HORIZONTAL SURFACE
MOUNT LATCHING MICRO-D

OMNETICS
CONNECTOR CORPORATION
7260 COMMERCE CIRCLE EAST
MINNEAPOLIS, MN 55432
WWW.OMNETICS.COM

CAGE CODE 61873	
DWG NO. A98083-015	
SHEET 2 OF 2	REV B
SCALE: 2:1	