

PART NO.	A98033-512	REV	ECO	DATE	APP
		A	104467	05-16-18	HV

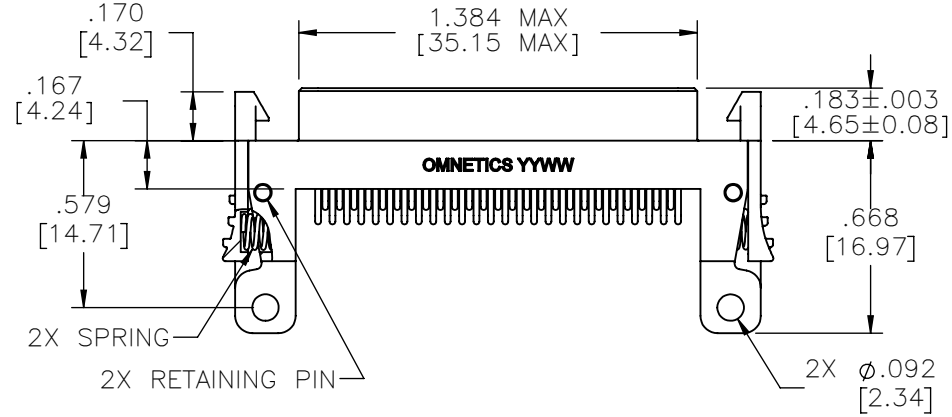
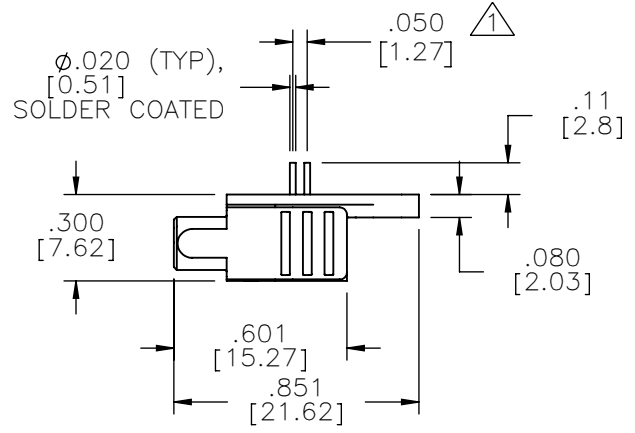
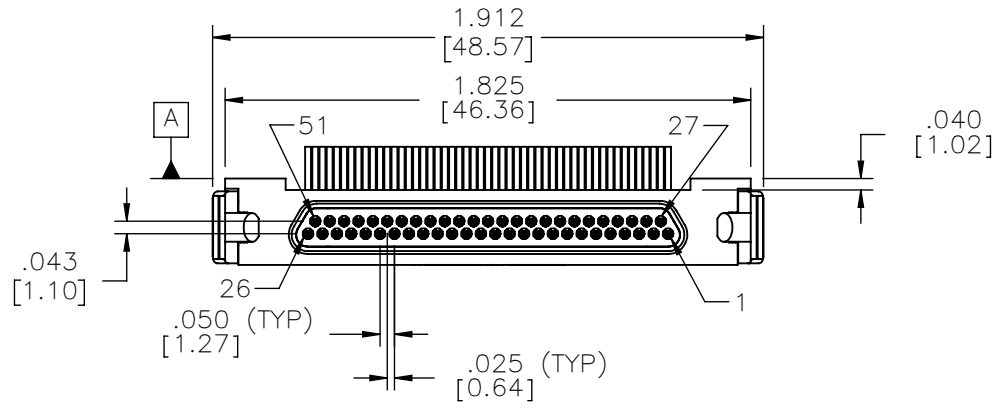
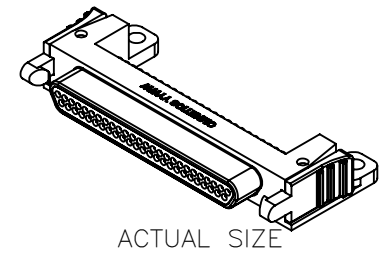
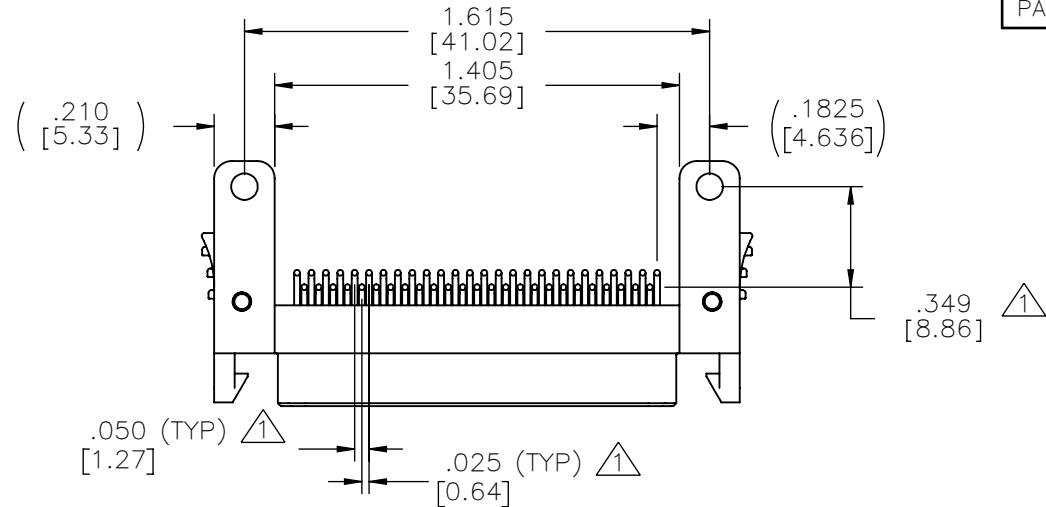

NOTES:
 DIMENSIONS IN [] ARE IN MILLIMETERS UNLESS OTHERWISE NOTED AND ARE FOR REFERENCE ONLY
 ⚠ TAIL DIMENSIONS APPLY AT PLANE A

THIRD ANGLE	THIS DRAWING CONTAINS CONFIDENTIAL AND PROPRIETARY INFORMATION WHICH IS THE PROPERTY OF OMNETICS CONNECTOR CORP. THIS DOCUMENT MAY NOT, IN WHOLE OR IN PART, BE DUPLICATED, OR DISCLOSED FOR ANY PURPOSE, WITHOUT WRITTEN PERMISSION FROM OMNETICS CONNECTOR CORP.	
-TOLERANCES-	DFTM. EDG	DATE 05-11-18
UNLESS OTHERWISE NOTED	CHK'D.	DATE
DIMENSIONS IN INCHES	APP'D.	DATE
2 PL DEC±.01	TITLE: (51) PIN MALE	
3 PL DEC±.005	90° BOARD MOUNT	
4 PL DEC±.0005	MICRO-D CONNECTOR	
ANGLES ± 1°		

OMNETICS CONNECTOR CORPORATION 7260 COMMERCE CIRCLE EAST MINNEAPOLIS, MN 55432 WWW.OMNETICS.COM	CAGE CODE 61873
	DWG NO. A98033-512
	SHEET 1 OF 2
	SCALE: 3:2
	REV A

PART NO.	A98033-512	REV	ECO	DATE	APP
		A	104467	05-16-18	HV

MATERIALS

HOUSING:
ALUMINUM 6061, NICKEL PLATE
(500 MICROINCHES MINIMUM)
PER SAE-AMS-2404

LATCH:
STAINLESS STEEL, NICKEL PLATE
PER SAE-AMS-2404

INSULATOR:
LIQUID CRYSTAL POLYMER (LCP)
PER ASTM D5138

CONTACT:
BERYLLIUM COPPER PER ASTM
B194, C17200, GOLD PLATED
PER ASTM B488, (HARD GOLD)
TYPE II CODE C, CLASS 1.27

TERMINATION:
SOLDER COATED WITH SN63A
PER J-STD-006 OR AMS-P-
81728

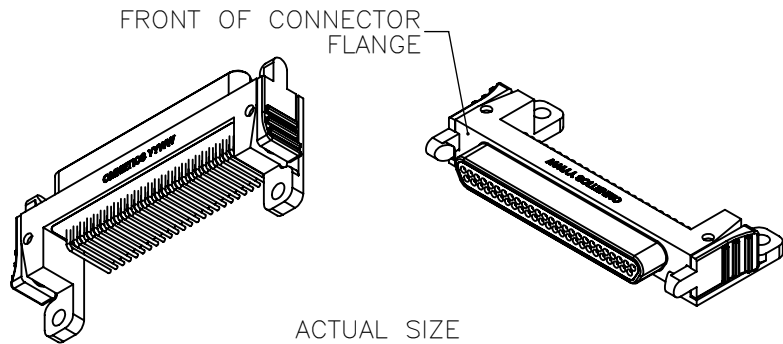
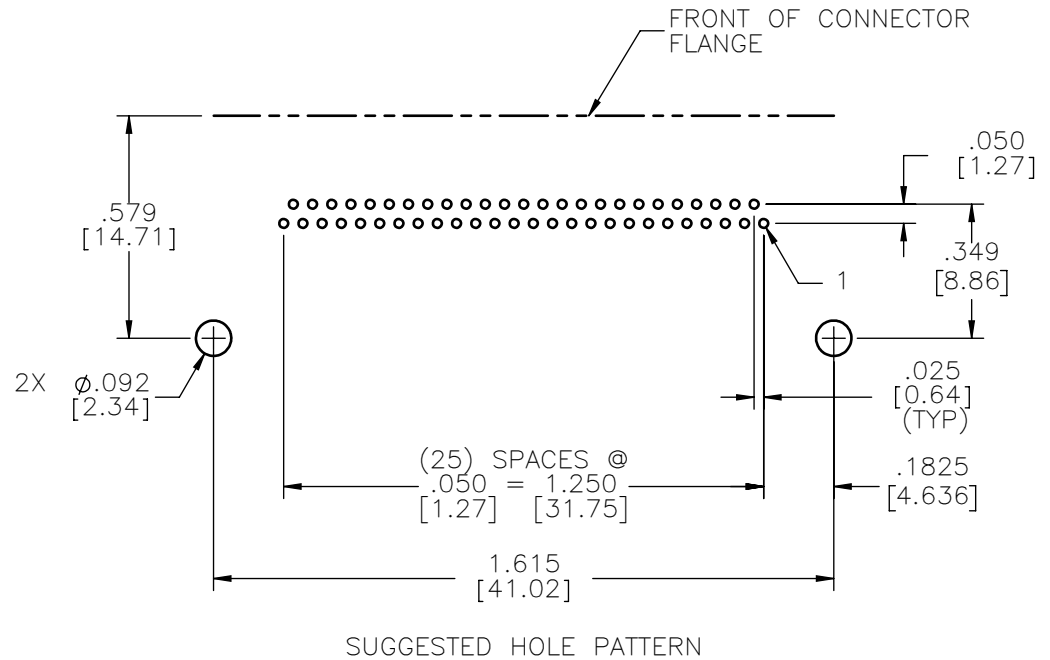

NOTE:

DIMENSIONS IN [] ARE IN MILLIMETERS UNLESS OTHERWISE NOTED AND ARE FOR REFERENCE ONLY

M	T	THIRD ANGLE
		-TOLERANCES-
S	C	UNLESS OTHERWISE NOTED
		DIMENSIONS IN INCHES
		2 PL DEC ± .01
		3 PL DEC ± .005
		4 PL DEC ± .0005
		ANGLES ± 1°

THIS DRAWING CONTAINS CONFIDENTIAL AND PROPRIETARY INFORMATION WHICH IS THE PROPERTY OF OMNETICS CONNECTOR CORP. THIS DOCUMENT MAY NOT, IN WHOLE OR IN PART, BE DUPLICATED, OR DISCLOSED FOR ANY PURPOSE, WITHOUT WRITTEN PERMISSION FROM OMNETICS CONNECTOR CORP.

DFTM. EDG	DATE
CHK'D.	05-11-18
APP'D.	DATE

TITLE:
(51) PIN MALE
90° BOARD MOUNT
MICRO-D CONNECTOR

OMNETICS
CONNECTOR CORPORATION
7260 COMMERCE CIRCLE EAST
MINNEAPOLIS, MN 55432
WWW.OMNETICS.COM

CAGE CODE 61873	
DWG NO. A98033-512	
SHEET 2 OF 2	REV A
SCALE: 2:1	