

PART NO.	A98033-025	REV	ECO	DATE	APP
		A	104484	05-21-18	TLM

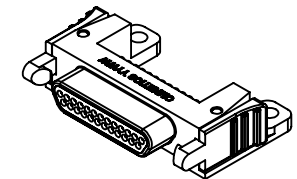

ACTUAL SIZE

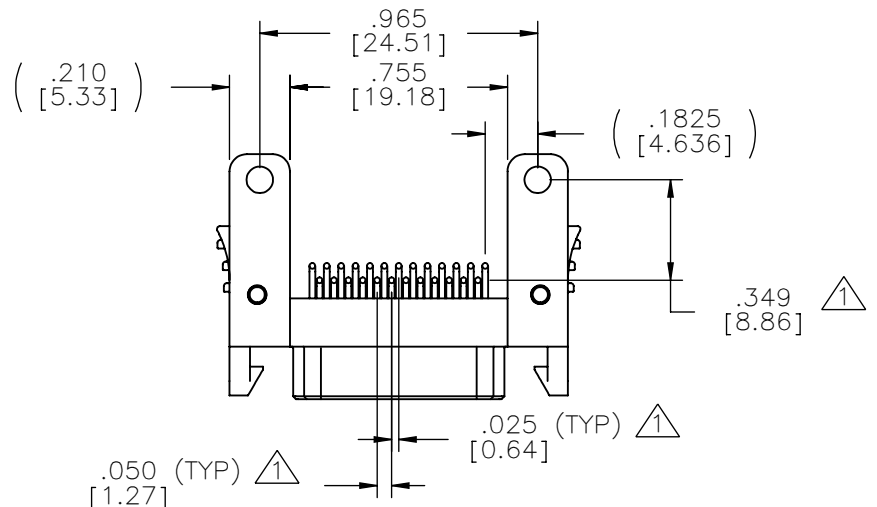
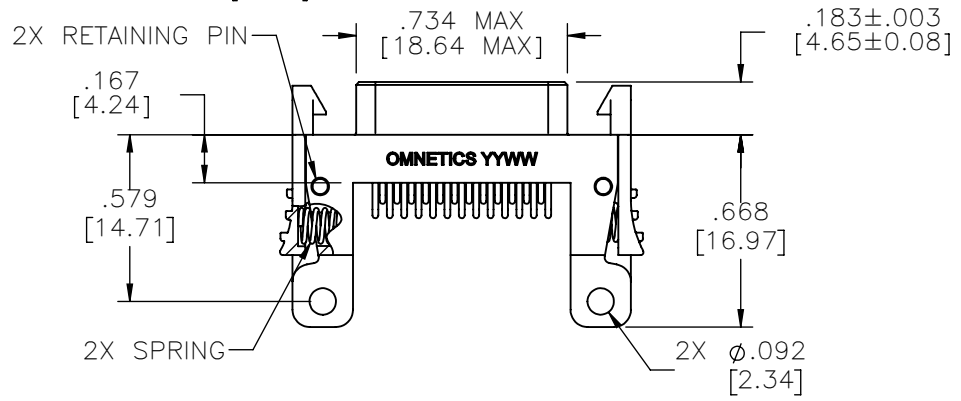
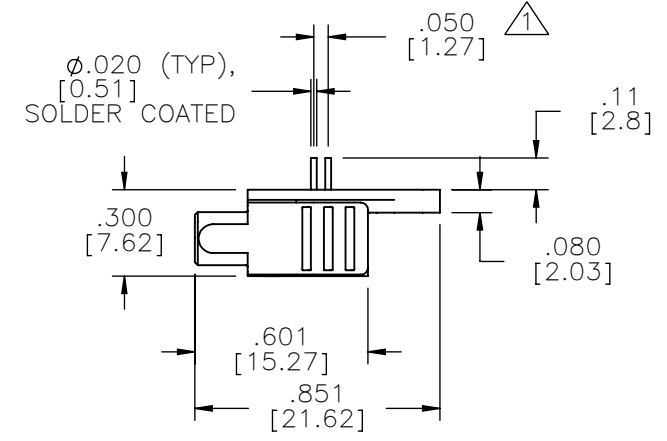
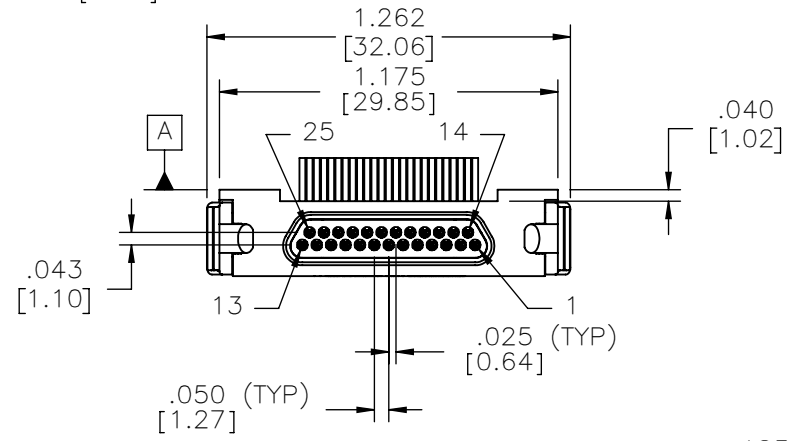

NOTES:
 DIMENSIONS IN [] ARE IN MILLIMETERS UNLESS OTHERWISE NOTED AND ARE FOR REFERENCE ONLY
 ⚠ TAIL DIMENSIONS APPLY AT PLANE A

MTC	THIRD ANGLE
	-TOLERANCES-
	UNLESS OTHERWISE NOTED
	DIMENSIONS IN INCHES
2	PL DEC ± .01
3	PL DEC ± .005
4	PL DEC ± .0005
	ANGLES ± 1°

THIS DRAWING CONTAINS CONFIDENTIAL AND PROPRIETARY INFORMATION WHICH IS THE PROPERTY OF OMNETICS CONNECTOR CORP. THIS DOCUMENT MAY NOT, IN WHOLE OR IN PART, BE DUPLICATED, OR DISCLOSED FOR ANY PURPOSE, WITHOUT WRITTEN PERMISSION FROM OMNETICS CONNECTOR CORP.	
DFTM. TLM	DATE 03-21-13
CHK'D.	DATE
APP'D.	DATE

TITLE:
 (25) PIN MALE
 90° BOARD MOUNT
 MICRO-D CONNECTOR

OMNETICS
 CONNECTOR CORPORATION
 7260 COMMERCE CIRCLE EAST
 MINNEAPOLIS, MN 55432
 WWW.OMNETICS.COM

CAGE CODE 61873
DWG NO. A98033-025
SHEET 1 OF 2
SCALE: 3:2
REV A

PART NO.	A98033-025	REV	ECO	DATE	APP
		A	104484	05-21-18	TLM

MATERIALS

- HOUSING:**
ALUMINUM 6061, NICKEL PLATE
(500 MICROINCHES MINIMUM)
PER SAE-AMS-2404
- INSULATOR:**
LIQUID CRYSTAL POLYMER (LCP)
PER ASTM D5138
- CONTACT:**
BERYLLIUM COPPER PER ASTM
B194, C17200, GOLD PLATED
PER ASTM B488, (HARD GOLD)
TYPE II CODE C, CLASS 1.27
- TERMINATION:**
SOLDER COATED WITH SN63A
PER J-STD-006 OR AMS-P-
81728
- LATCH:**
STAINLESS STEEL, NICKEL PLATE
PER SAE-AMS-2404

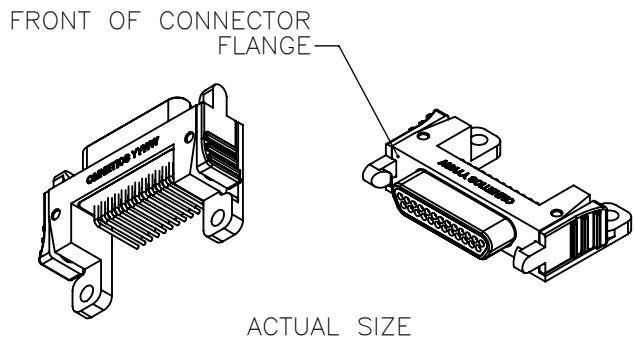
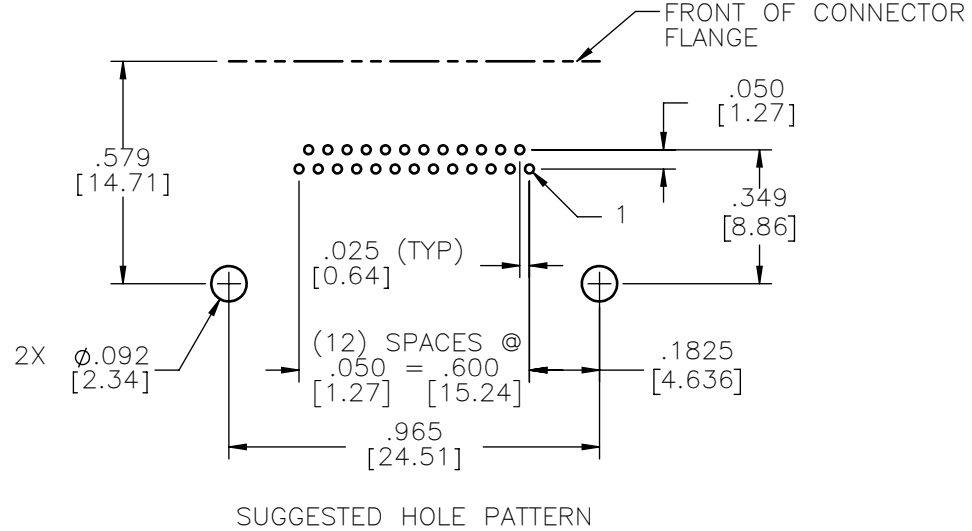

NOTE:
DIMENSIONS IN [] ARE IN
MILLIMETERS UNLESS
OTHERWISE NOTED AND ARE
FOR REFERENCE ONLY

MCTC LMDP SLDW	THIRD ANGLE
	-TOLERANCES-
	UNLESS OTHERWISE NOTED
	DIMENSIONS IN INCHES
2 PL DEC ± .01	
3 PL DEC ± .005	
4 PL DEC ± .0005	
ANGLES ± 1°	

THIS DRAWING CONTAINS CONFIDENTIAL AND PROPRIETARY INFORMATION WHICH IS THE PROPERTY OF OMNETICS CONNECTOR CORP. THIS DOCUMENT MAY NOT, IN WHOLE OR IN PART, BE DUPLICATED, OR DISCLOSED FOR ANY PURPOSE, WITHOUT WRITTEN PERMISSION FROM OMNETICS CONNECTOR CORP.	
DFTM. TLM	DATE 03-21-13
CHK'D.	DATE
APP'D.	DATE
TITLE: (25) PIN MALE 90° BOARD MOUNT MICRO-D CONNECTOR	

OMNETICS
CONNECTOR CORPORATION
7260 COMMERCE CIRCLE EAST
MINNEAPOLIS, MN 55432
WWW.OMNETICS.COM

CAGE CODE 61873	
DWG NO. A98033-025	
SHEET 2 OF 2	REV A
SCALE: 2:1	