

PART NO.	A98033-009	REV	ECO	DATE	APP
		A	106314	04-02-2020	TLM

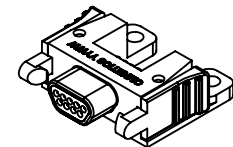

ACTUAL SIZE

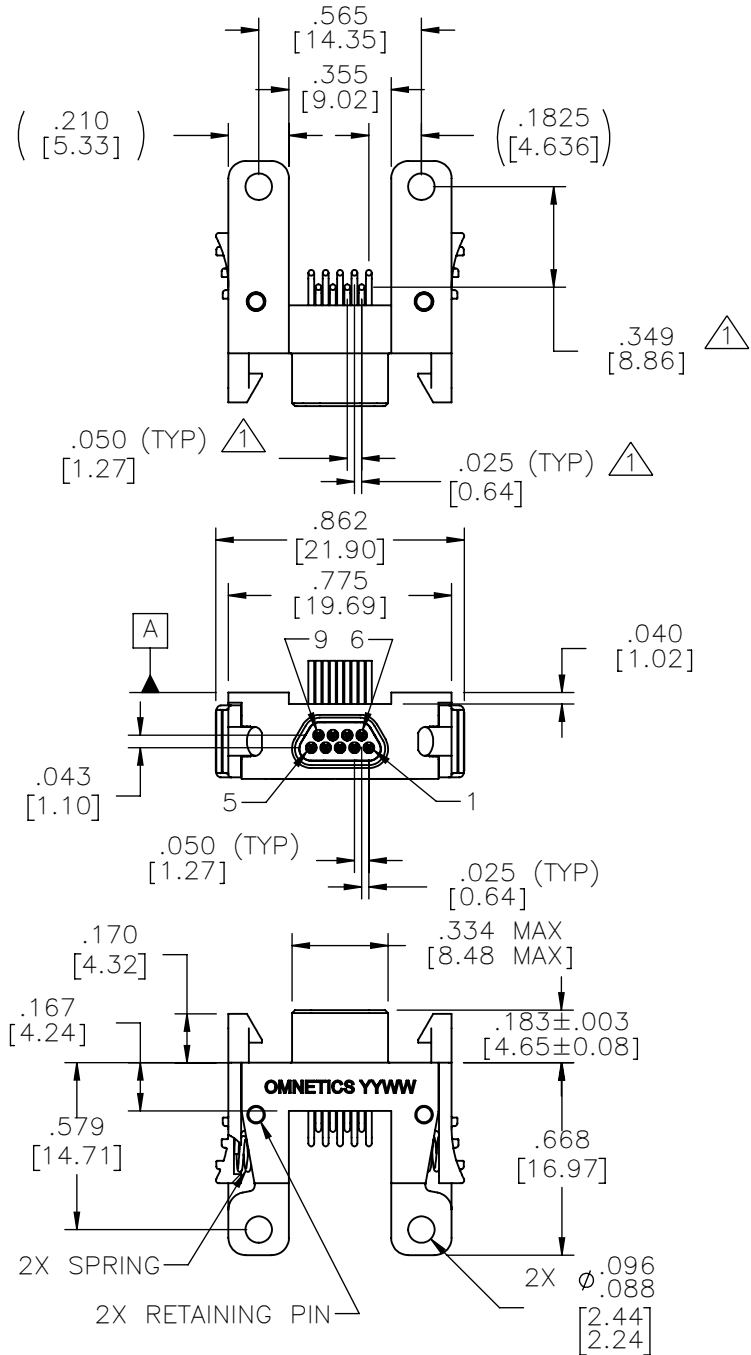
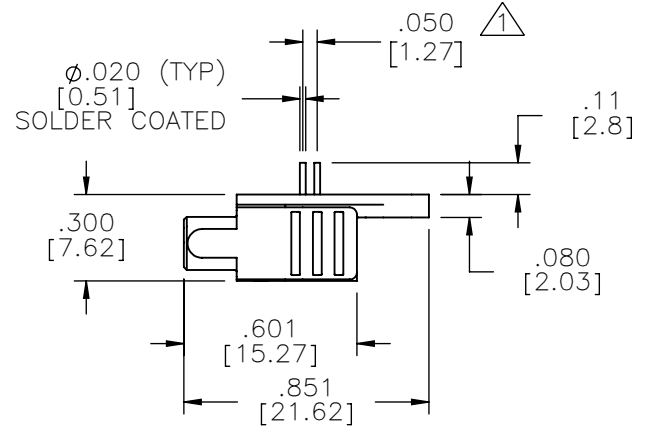

NOTES:
 DIMENSIONS IN [] ARE IN MILLIMETERS UNLESS OTHERWISE NOTED AND ARE FOR REFERENCE ONLY

△ TAIL DIMENSIONS APPLY AT PLANE A

THIRD ANGLE	
- TOLERANCES -	
UNLESS OTHERWISE NOTED	
DIMENSIONS IN INCHES	
2 PL DEC	± .01
3 PL DEC	± .005
4 PL DEC	± .0005
ANGLES ± 1°	

THIS DRAWING CONTAINS CONFIDENTIAL AND PROPRIETARY INFORMATION WHICH IS THE PROPERTY OF OMNETICS CONNECTOR CORP. THIS DOCUMENT MAY NOT, IN WHOLE OR IN PART, BE DUPLICATED, OR DISCLOSED FOR ANY PURPOSE, WITHOUT WRITTEN PERMISSION FROM OMNETICS CONNECTOR CORP.	
DFTM.	TLM
DATE	03-24-20
CHK'D.	
DATE	
APP'D.	
DATE	

TITLE:
 (9) PIN MALE
 90° BOARD MOUNT
 MICRO-D CONNECTOR

OMNETICS
 CONNECTOR CORPORATION
 7260 COMMERCE CIRCLE EAST
 MINNEAPOLIS, MN 55432
 WWW.OMNETICS.COM

CAGE CODE 61873	
DWG NO. A98033-009	
SHEET 1 OF 2	REV A
SCALE: 3:2	

PART NO.	A98033-009	REV	ECO	DATE	APP
		A	106314	04-02-2020	TLM

MATERIALS

HOUSING:
ALUMINUM 6061, NICKEL PLATE
(500 MICROINCHES MINIMUM)
PER SAE-AMS-2404

LATCH:
STAINLESS STEEL, NICKEL PLATE
PER SAE-AMS-2404

INSULATOR:
LIQUID CRYSTAL POLYMER (LCP)
PER ASTM D5138

CONTACT:
BERYLLIUM COPPER PER ASTM
B194, C17200, GOLD PLATED
PER ASTM B488, (HARD GOLD)
TYPE II CODE C, CLASS 1.27

TERMINATION:
SOLDER COATED WITH SN63A
PER J-STD-006 OR AMS-P-
81728

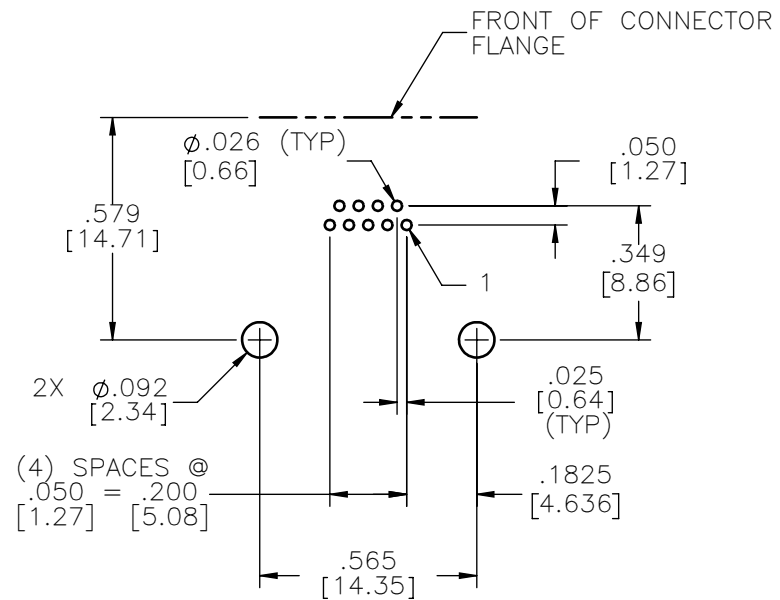

SUGGESTED HOLE PATTERN

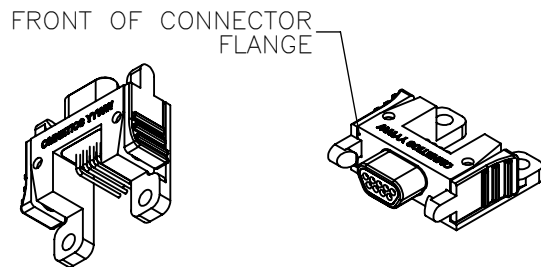

ACTUAL SIZE

NOTE:

DIMENSIONS IN [] ARE IN MILLIMETERS UNLESS OTHERWISE NOTED AND ARE FOR REFERENCE ONLY

THIRD ANGLE	—TOLERANCES—
	UNLESS OTHERWISE NOTED
DIMENSIONS IN INCHES	2 PL DEC ± .01
	3 PL DEC ± .005
	4 PL DEC ± .0005
	ANGLES ± 1°

THIS DRAWING CONTAINS CONFIDENTIAL AND PROPRIETARY INFORMATION WHICH IS THE PROPERTY OF OMNETICS CONNECTOR CORP. THIS DOCUMENT MAY NOT, IN WHOLE OR IN PART, BE DUPLICATED, OR DISCLOSED FOR ANY PURPOSE, WITHOUT WRITTEN PERMISSION FROM OMNETICS CONNECTOR CORP.

DFTM.	TLM	DATE	03-24-20
CHK'D.		DATE	
APP'D.		DATE	

TITLE:
**(9) PIN MALE
90° BOARD MOUNT
MICRO-D CONNECTOR**

OMNETICS
CONNECTOR CORPORATION
7260 COMMERCE CIRCLE EAST
MINNEAPOLIS, MN 55432
WWW.OMNETICS.COM

CAGE CODE 61873	
DWG NO. A98033-009	
SHEET 2 OF 2	REV A
SCALE: 2:1	