

MATERIALS

HOUSING:

ALUMINUM 6061-T6,
NICKEL PLATE PER SAE-
AMS-2404

LATCH:

STAINLESS STEEL,
NICKEL PLATE PER SAE-
AMS-2404

INSULATOR:

LIQUID CRYSTAL
POLYMER (LCP) PER
ASTM D5138

CONTACT:

BERYLLIUM COPPER PER
ASTM B194, C17200
AND COPPER ALLOY PER
MIL-DTL-83513, GOLD
PLATED PER ASTM B488,
(HARD GOLD) TYPE II
CODE C, CLASS 1.27

RETAINING PIN:

18-8 STAINLESS STEEL

SPRING:

300 SERIES STAINLESS
STEEL

PART NO.	A98027-513	REV	ECO	DATE	APP
		A	103252	02-17-17	TLM

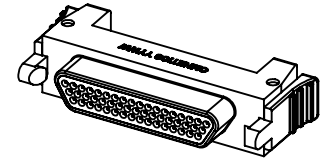
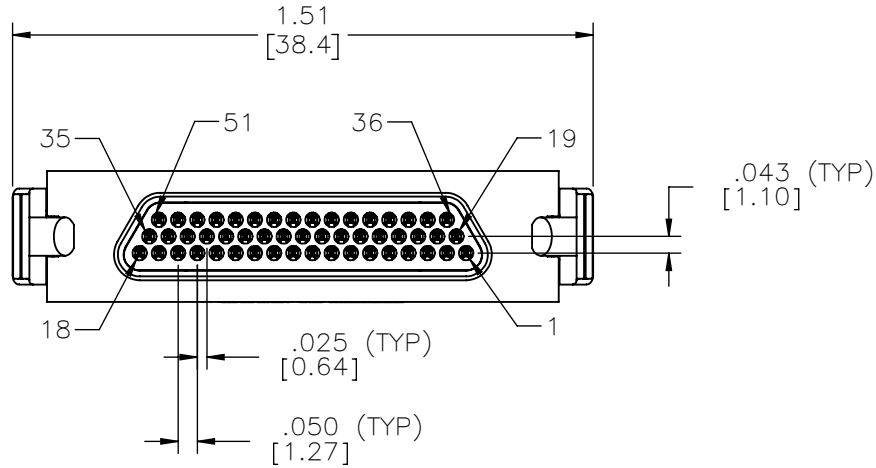

ACTUAL SIZE

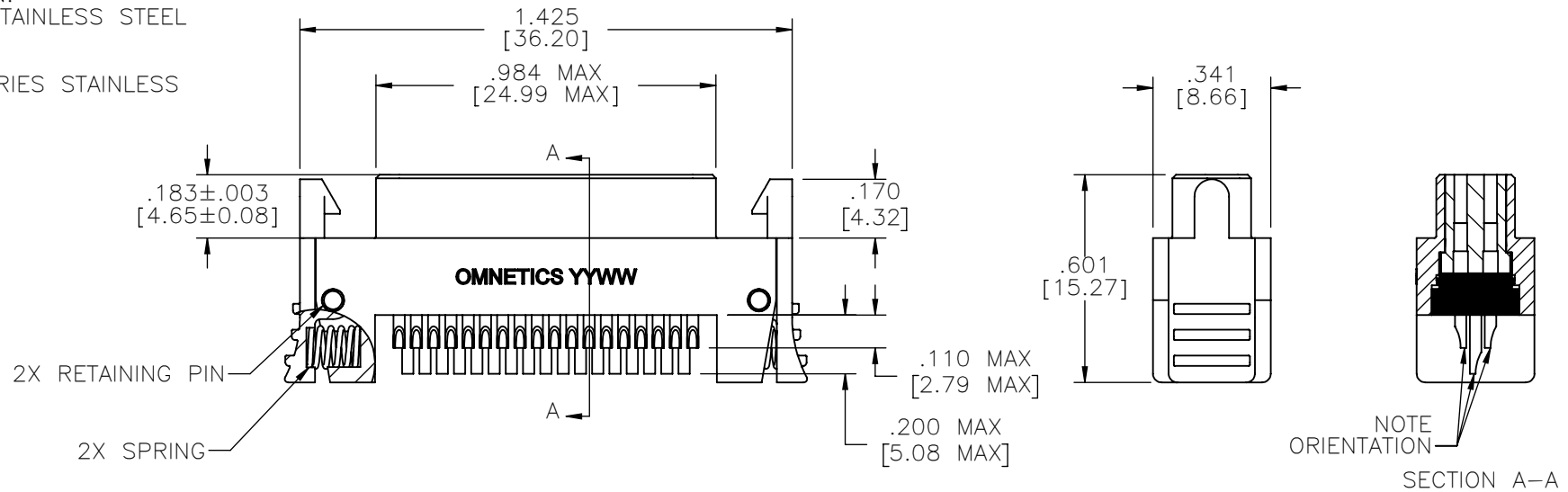

NOTE:

DIMENSIONS IN [] ARE IN
MILLIMETERS UNLESS
OTHERWISE NOTED AND ARE
FOR REFERENCE ONLY

THIRD ANGLE	UNLESS OTHERWISE NOTED
-TOLERANCES-	DIMENSIONS IN INCHES
2 PL DEC± .01	
3 PL DEC± .005	
4 PL DEC± .0005	
ANGLES ± 1°	

THIS DRAWING CONTAINS CONFIDENTIAL AND PROPRIETARY INFORMATION WHICH IS THE PROPERTY OF OMNETICS CONNECTOR CORP. THIS DOCUMENT MAY NOT, IN WHOLE OR IN PART, BE DUPLICATED, OR DISCLOSED FOR ANY PURPOSE, WITHOUT WRITTEN PERMISSION FROM OMNETICS CONNECTOR CORP.	
DFTM. TLM	DATE 02-09-17
CHK'D.	DATE
APP'D.	DATE
TITLE: (51) PIN MALE MICRO-D CONNECTOR W/LATCHES	

OMNETICS
CONNECTOR CORPORATION
7260 COMMERCE CIRCLE EAST
MINNEAPOLIS, MN 55432
WWW.OMNETICS.COM

CAGE CODE 61873	
DWG NO. A98027-513	
SHEET 1 OF 1	REV A
SCALE: 2:1	

RoHS