

MATERIALS & SPECIFICATIONS

PART NO.	A55200-031	REV	ECO	DATE	APP
		E	102600	05-18-16	TLM

HOUSING:
ALUMINUM 6061-T6, NICKEL PLATE PER SAE-AMS-2404

INSULATOR:
THERMOPLASTIC PER MIL-DTL-32139

CONTACT:
COPPER ALLOY PER MIL-DTL-32139, GOLD PLATED PER ASTM B488, (HARD GOLD) TYPE II CODE C, CLASS 1.27

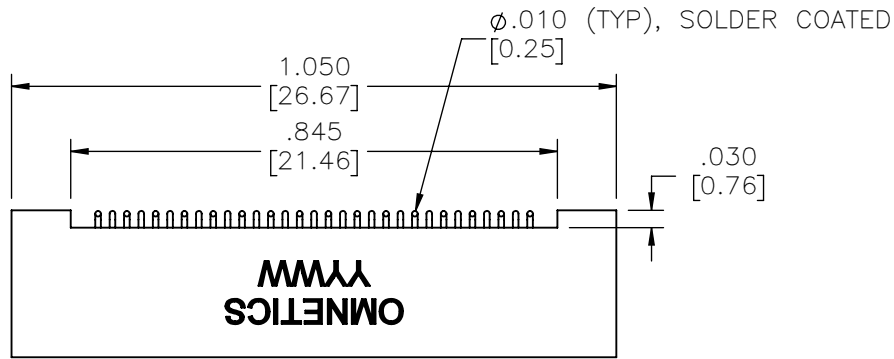

TERMINATION:
SOLDER COATED WITH SN63A PER J-STD-006

CURRENT RATING:
1 AMP MAX PER MIL-DTL-32139

CONTACT RESISTANCE:
71 MILLIOHM MAX (71MV DROP MAX @ 1.0 AMPS) PER MIL-DTL-32139

PERFORMANCE:
PRODUCT FAMILY TESTED TO AND PASSED THE PERFORMANCE SPECIFICATIONS OF TABLE VIII OF MIL-DTL-32139

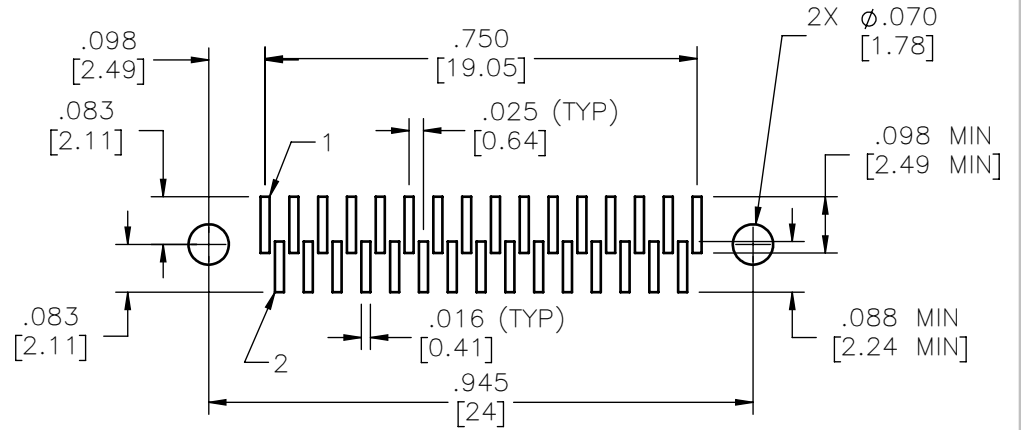

SUGGESTED PAD LAYOUT

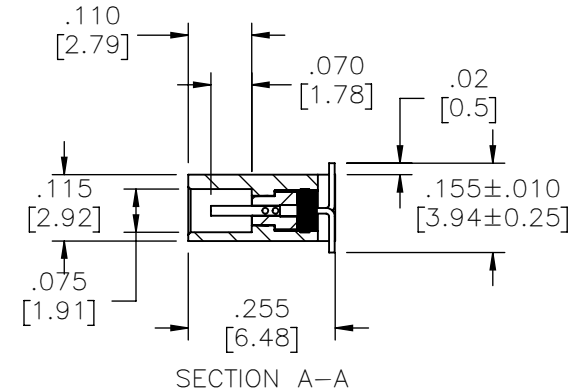
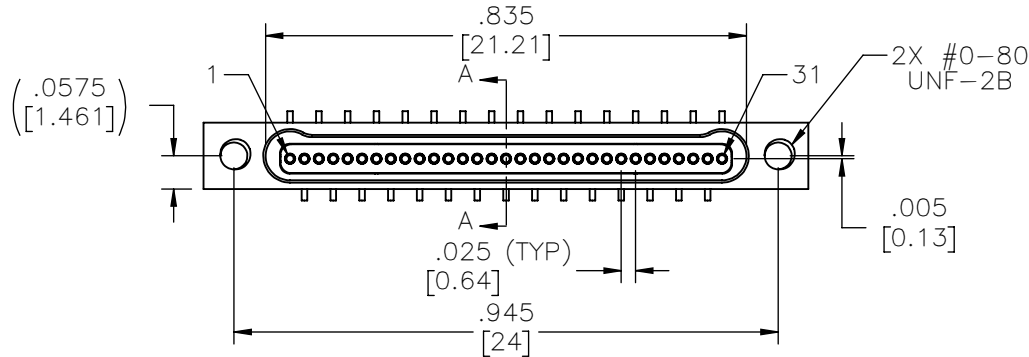
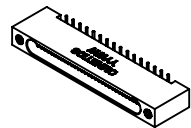

NOTE:

DIMENSIONS IN [] ARE IN MILLIMETERS UNLESS OTHERWISE NOTED AND ARE FOR REFERENCE ONLY

MBS SLDW	THIRD ANGLE
	-TOLERANCES-
	UNLESS OTHERWISE NOTED
	DIMENSIONS IN INCHES
2	PL DEC ± .01
3	PL DEC ± .005
4	PL DEC ± .0005
	ANGLES ± 1°

THIS DRAWING CONTAINS CONFIDENTIAL AND PROPRIETARY INFORMATION WHICH IS THE PROPERTY OF OMNETICS CONNECTOR CORP. THIS DOCUMENT MAY NOT, IN WHOLE OR IN PART, BE DUPLICATED, OR DISCLOSED FOR ANY PURPOSE, WITHOUT WRITTEN PERMISSION FROM OMNETICS CONNECTOR CORP.

DFTM.	DGJ	DATE	10-13-11	TITLE:	(31) SOCKET FEMALE
CHK'D.		DATE			Bi-Lobe® CONNECTOR
APP'D.		DATE			

OMNETICS
CONNECTOR CORPORATION
7260 COMMERCE CIRCLE EAST
MINNEAPOLIS, MN 55432
WWW.OMNETICS.COM

CAGE CODE	61873
DWG NO.	A55200-031
SHEET 1 OF 1	REV E
SCALE:	3:1