

MATERIALS & SPECIFICATIONS

PART NO.	A55200-025	REV	ECO	DATE	APP
		E	102600	05-18-16	TLM

HOUSING:
ALUMINUM 6061-T6, NICKEL
PLATE PER SAE-AMS-2404

INSULATOR:
THERMOPLASTIC PER MIL-
DTL-32139

CONTACT:
COPPER ALLOY PER MIL-DTL-
32139, GOLD PLATED PER
ASTM B488, (HARD GOLD)
TYPE II CODE C, CLASS 1.27

TERMINATION:
SOLDER COATED WITH SN63A
PER J-STD-006

CURRENT RATING:
1 AMP MAX PER MIL-DTL-
32139

CONTACT RESISTANCE:
71 MILLIOHM MAX (71MV
DROP MAX @ 1.0 AMPS) PER
MIL-DTL-32139

PERFORMANCE:
PRODUCT FAMILY TESTED TO
AND PASSED THE
PERFORMANCE SPECIFICATIONS
OF TABLE VIII OF MIL-DTL-
32139

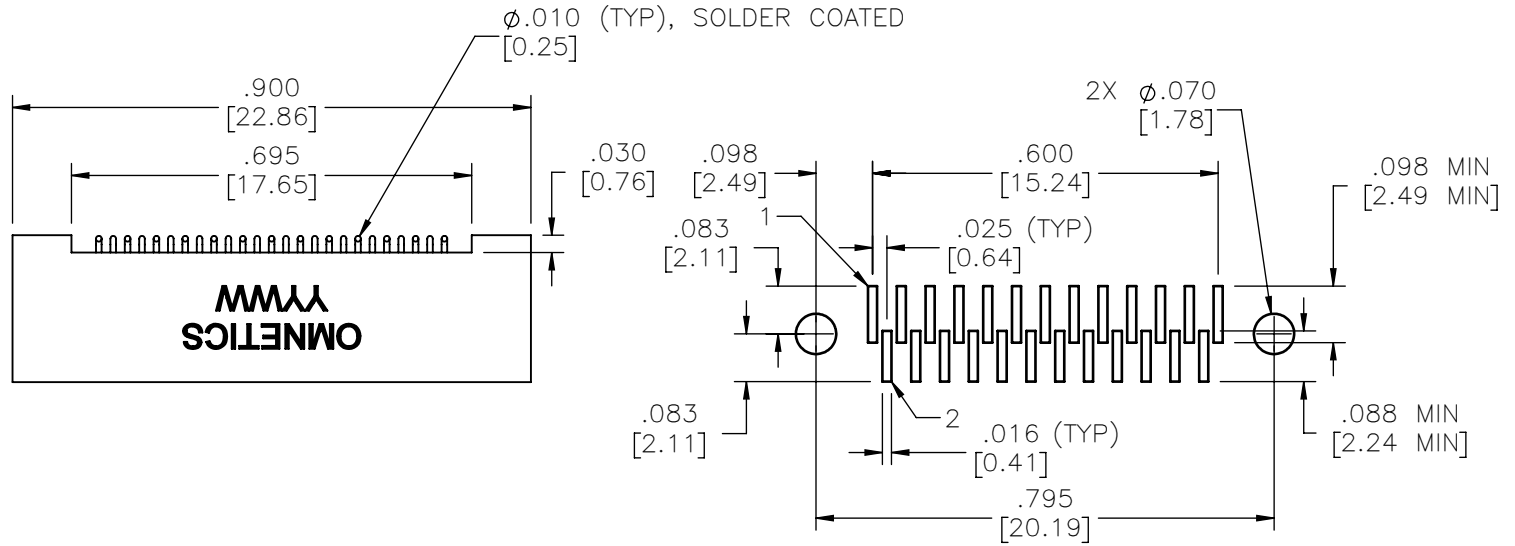

SUGGESTED PAD LAYOUT

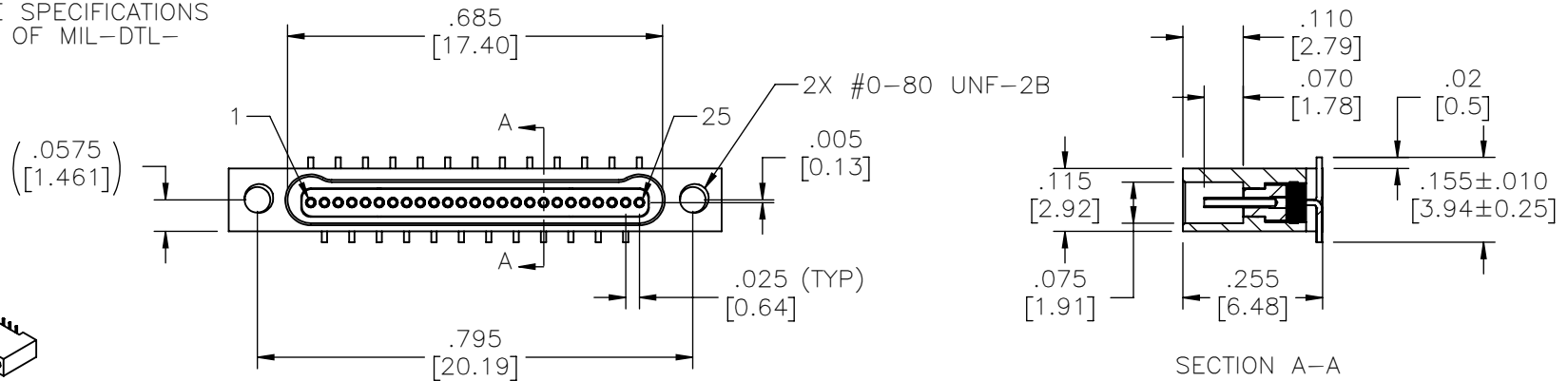

SECTION A-A

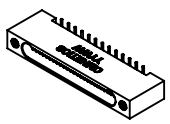

ACTUAL SIZE

NOTE:
DIMENSIONS IN [] ARE IN
MILLIMETERS UNLESS
OTHERWISE NOTED AND ARE
FOR REFERENCE ONLY

MBS SLDW	THIRD ANGLE	THIS DRAWING CONTAINS CONFIDENTIAL AND PROPRIETARY INFORMATION WHICH IS THE PROPERTY OF OMNETICS CONNECTOR CORP. THIS DOCUMENT MAY NOT, IN WHOLE OR IN PART, BE DUPLICATED, OR DISCLOSED FOR ANY PURPOSE, WITHOUT WRITTEN PERMISSION FROM OMNETICS CONNECTOR CORP.	
	- TOLERANCES - UNLESS OTHERWISE NOTED	DFTM. DGJ	DATE 10-13-11
	DIMENSIONS IN INCHES	CHK'D.	DATE
	2 PL DEC ± .01 3 PL DEC ± .005 4 PL DEC ± .0005 ANGLES ± 1°	APP'D.	DATE

TITLE:
(25) SOCKET FEMALE
Bi-Lobe® CONNECTOR

OMNETICS
CONNECTOR CORPORATION
7260 COMMERCE CIRCLE EAST
MINNEAPOLIS, MN 55432
WWW.OMNETICS.COM

CAGE CODE 61873
DWG NO. A55200-025
SHEET 1 OF 1
SCALE: 3:1
REV E