

MATERIALS & SPECIFICATIONS

HOUSING:
ALUMINUM 6061-T6, NICKEL
PLATE PER SAE-AMS-2404

INSULATOR:
LIQUID CRYSTAL POLYMER
(LCP) PER ASTM D5138

CONTACTS:
COPPER ALLOY PER MIL-DTL-
32139, GOLD PLATED PER
ASTM B488, (HARD GOLD)
TYPE II CODE C, CLASS 1.27

TERMINATION:
SOLDER COATED WITH SN63A
PER J-STD-006

CURRENT RATING:
1 AMP MAX PER MIL-DTL-
32139

CONTACT RESISTANCE:
71 MILLIOHM MAX (71mV
DROP MAX) @ 1.0 AMPS PER
MIL-DTL-32139

PERFORMANCE:
PRODUCT FAMILY TESTED TO
AND PASSED THE
PERFORMANCE SPECIFICATIONS
OF TABLE VIII OF MIL-DTL-
32139

PART NO.	A29900-085	REV	ECO	DATE	APP
		C	102608	05-20-16	TLM

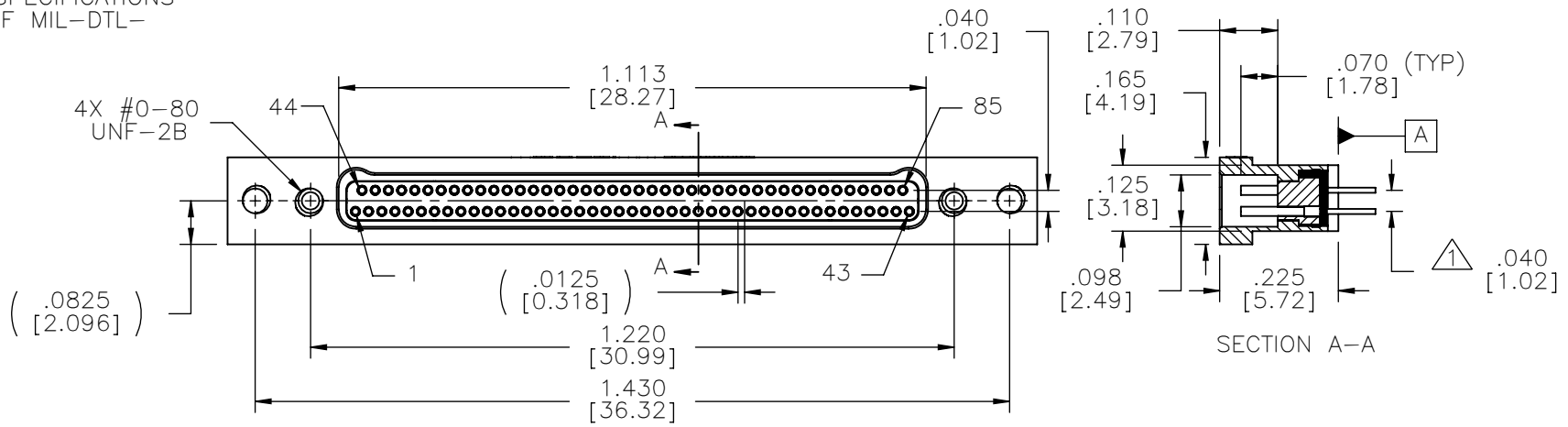
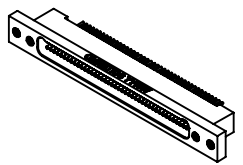
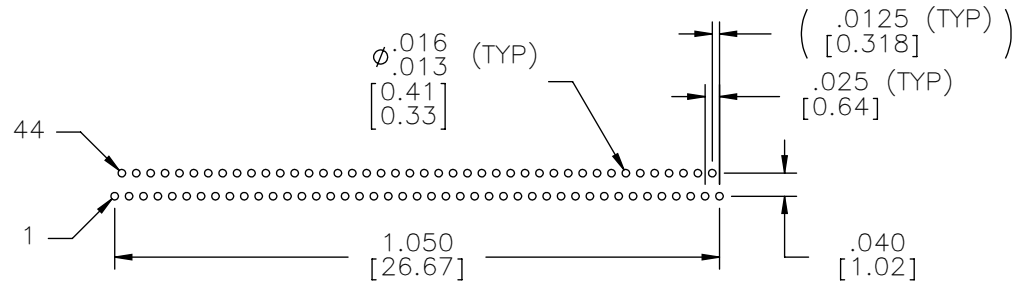
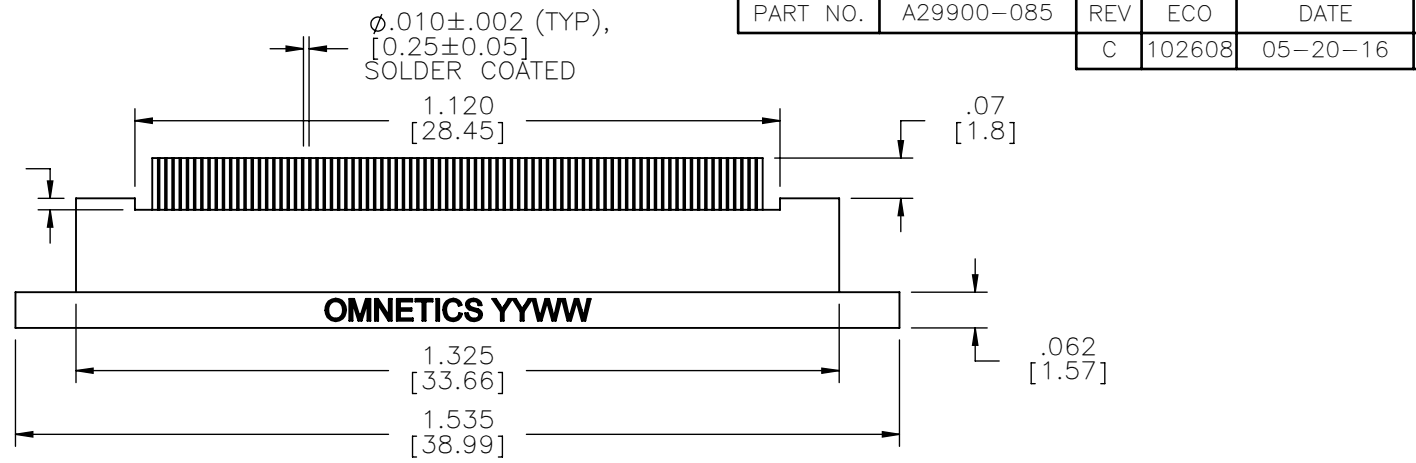

NOTES:
▲ TAIL DIMENSIONS APPLY
AT PLANE [A]

DIMENSIONS IN [] ARE IN
MILLIMETERS UNLESS
OTHERWISE NOTED AND ARE
FOR REFERENCE ONLY

MCS LOSMV	THIRD ANGLE	THIS DRAWING CONTAINS CONFIDENTIAL AND PROPRIETARY INFORMATION WHICH IS THE PROPERTY OF OMNETICS CONNECTOR CORP. THIS DOCUMENT MAY NOT, IN WHOLE OR IN PART, BE DUPLICATED, OR DISCLOSED FOR ANY PURPOSE, WITHOUT WRITTEN PERMISSION FROM OMNETICS CONNECTOR CORP.	DATE	TITLE:
	-TOLERANCES-		07-14-11	(85) SOCKET FEMALE
	UNLESS OTHERWISE NOTED		DATE	Bi-Lobe® CONNECTOR
	DIMENSIONS IN INCHES		DATE	
2 PL DEC ± .01	DFTM. DGJ	APP'D.		
3 PL DEC ± .005	CHK'D.			
4 PL DEC ± .0005				
ANGLES ± 1°				

OMNETICS
CONNECTOR CORPORATION
7260 COMMERCE CIRCLE EAST
MINNEAPOLIS, MN 55432
WWW.OMNETICS.COM

CAGE CODE **61873**
DWG NO. **A29900-085**
SHEET 1 OF 1
SCALE: 3:1

REV
C