

MATERIALS & SPECIFICATIONS

PART NO.	A29900-025	REV	ECO	DATE	APP
		K	102608	05-20-16	TLM

HOUSING:
ALUMINUM 6061-T6, NICKEL
PLATE PER SAE-AMS-2404

INSULATOR:
LIQUID CRYSTAL POLYMER (LCP)
PER ASTM D5138

CONTACTS:
COPPER ALLOY PER MIL-DTL-
32139, GOLD PLATED PER ASTM
B488, (HARD GOLD) TYPE II
CODE C, CLASS 1.27

TERMINATION:
SOLDER COATED WITH SN63A
PER J-STD-006

CURRENT RATING:
1 AMP MAX PER MIL-DTL-32139

CONTACT RESISTANCE:
71 MILLIOHM MAX (71mV DROP
MAX) @ 1.0 AMPS PER MIL-
DTL-32139

PERFORMANCE:
PRODUCT FAMILY TESTED TO AND
PASSED THE PERFORMANCE
SPECIFICATIONS OF TABLE VIII OF
MIL-DTL-32139

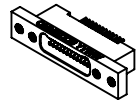
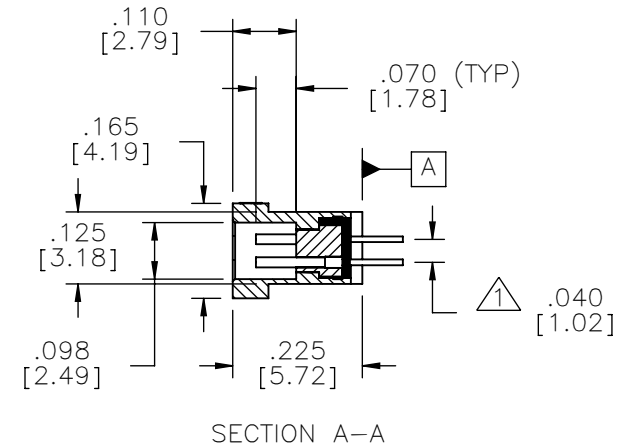
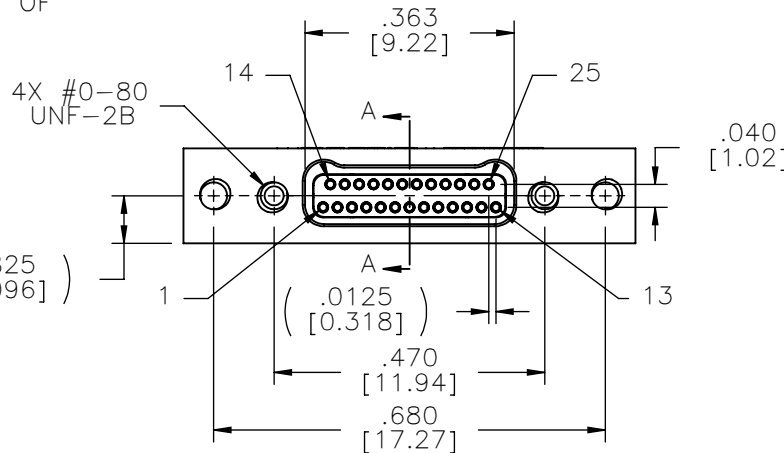
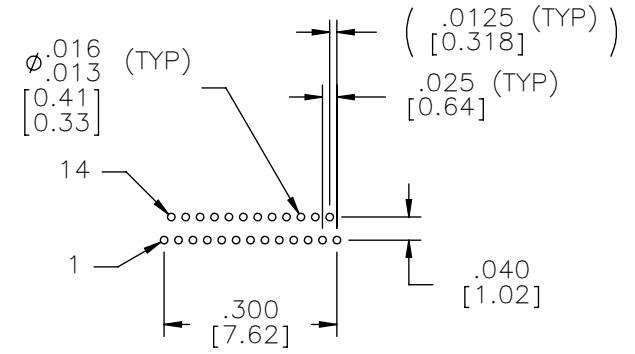
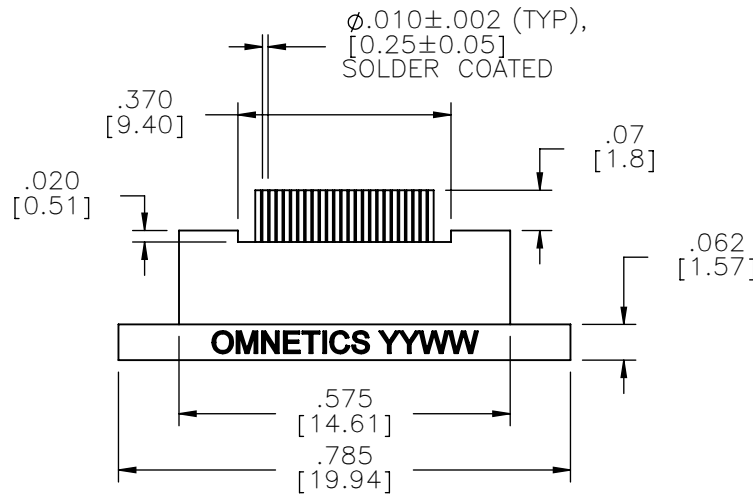

ACTUAL SIZE

NOTES:

\triangle TAIL DIMENSIONS APPLY
AT PLANE [A]

DIMENSIONS IN [] ARE IN
MILLIMETERS UNLESS
OTHERWISE NOTED AND ARE
FOR REFERENCE ONLY

MGT'S SLOTT	THIRD ANGLE ϕ
	- TOLERANCES -
	UNLESS OTHERWISE NOTED
	DIMENSIONS IN INCHES
2 PL DEC ± .01	
3 PL DEC ± .005	
4 PL DEC ± .0005	
ANGLES ± 1°	

THIS DRAWING CONTAINS CONFIDENTIAL AND PROPRIETARY INFORMATION WHICH IS THE PROPERTY OF OMNETICS CONNECTOR CORP. THIS DOCUMENT MAY NOT, IN WHOLE OR IN PART, BE DUPLICATED, OR DISCLOSED FOR ANY PURPOSE, WITHOUT WRITTEN PERMISSION FROM OMNETICS CONNECTOR CORP.	
DFTM. AAS	DATE 05-17-04
CHK'D.	DATE
APP'D.	DATE
TITLE: (25) SOCKET FEMALE Bi-Lobe® CONNECTOR	

OMNETICS
CONNECTOR CORPORATION
7260 COMMERCE CIRCLE EAST
MINNEAPOLIS, MN 55432
WWW.OMNETICS.COM

CAGE CODE 61873
DWG NO. A29900-025
SHEET 1 OF 1
SCALE: 3:1
REV K