

# MATERIALS & SPECIFICATIONS

PART NO.	A29800-009	REV	ECO	DATE	05-23-16	APP	TLM
		G	102616				

**HOUSING:**  
ALUMINUM 6061-T6, NICKEL  
PLATE PER SAE-AMS-2404

**INSULATOR:**  
LIQUID CRYSTAL POLYMER (LCP)  
PER ASTM D5138

**CONTACTS:**  
COPPER ALLOY PER MIL-DTL-  
32139, GOLD PLATED PER ASTM  
B488, (HARD GOLD) TYPE II  
CODE C, CLASS 1.27

**TERMINATION:**  
SOLDER COATED WITH SN63A  
PER J-STD-006

**CURRENT RATING:**  
1 AMP MAX PER MIL-DTL-32139

**CONTACT RESISTANCE:**  
71 MILLIOHM MAX (71mV DROP  
MAX) @ 1.0 AMPS PER MIL-  
DTL-32139

**PERFORMANCE:**  
PRODUCT FAMILY TESTED TO AND  
PASSED THE PERFORMANCE  
SPECIFICATIONS OF TABLE VIII OF  
MIL-DTL-32139

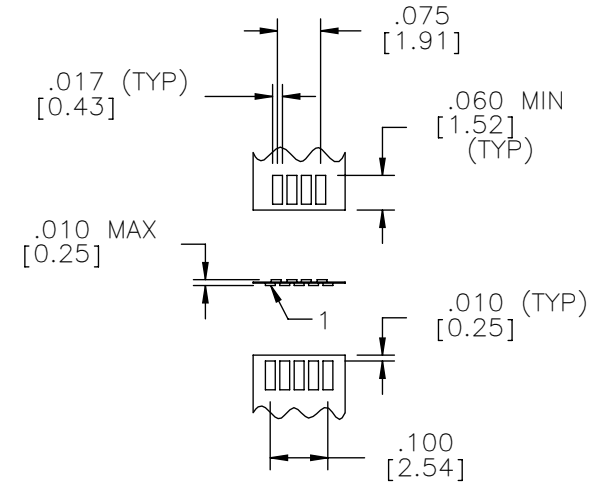
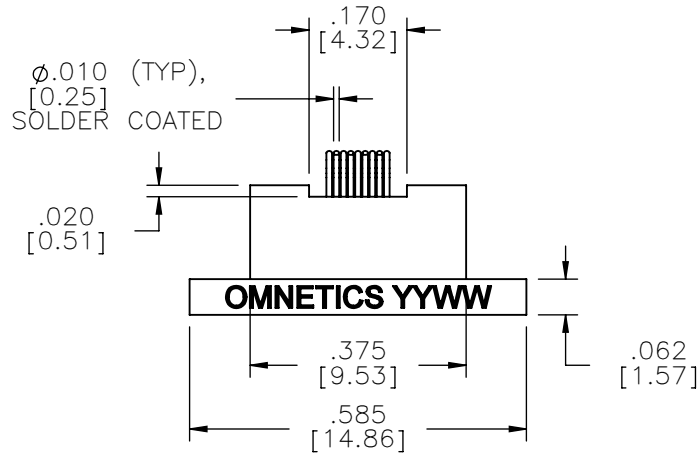

SUGGESTED PAD LAYOUT

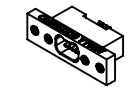
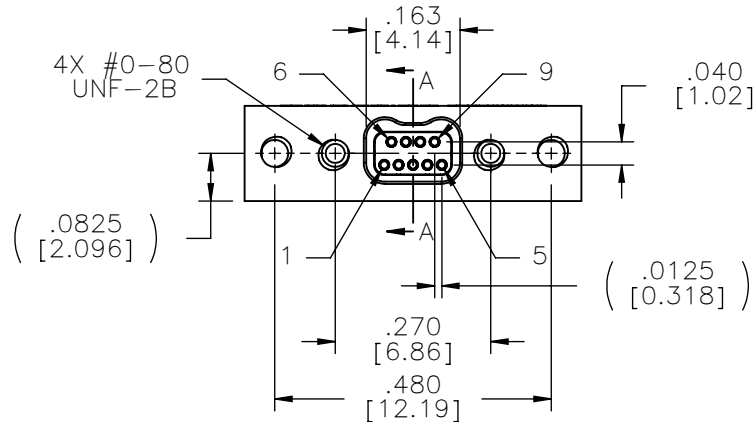

ACTUAL SIZE

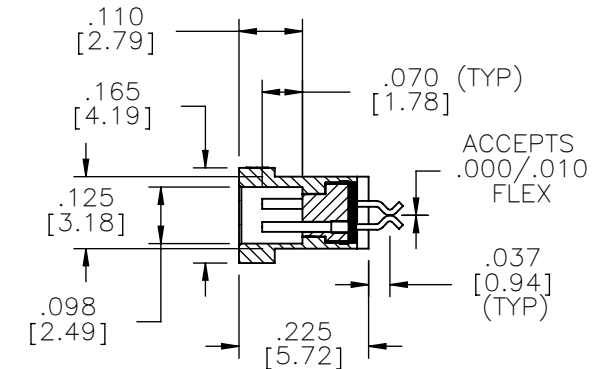

SECTION A-A

**NOTE:**

DIMENSIONS IN [ ] ARE IN  
MILLIMETERS UNLESS  
OTHERWISE NOTED AND ARE  
FOR REFERENCE ONLY

MGT SLOP SLOW	THIRD ANGLE
	-TOLERANCES-
	UNLESS OTHERWISE NOTED
	DIMENSIONS IN INCHES
2	PL DEC ± .01
3	PL DEC ± .005
4	PL DEC ± .0005
	ANGLES ± 1°

THIS DRAWING CONTAINS CONFIDENTIAL AND PROPRIETARY INFORMATION WHICH IS THE PROPERTY OF OMNETICS CONNECTOR CORP. THIS DOCUMENT MAY NOT, IN WHOLE OR IN PART, BE DUPLICATED, OR DISCLOSED FOR ANY PURPOSE, WITHOUT WRITTEN PERMISSION FROM OMNETICS CONNECTOR CORP.	
DFTM. AAS	DATE 05-14-04
CHK'D.	DATE
APP'D.	DATE
TITLE: (9) SOCKET FEMALE Bi-Lobe® CONNECTOR	

**OMNETICS**  
CONNECTOR CORPORATION  
7260 COMMERCE CIRCLE EAST  
MINNEAPOLIS, MN 55432  
WWW.OMNETICS.COM

CAGE CODE 61873	
DWG NO. A29800-009	
SHEET 1 OF 1	REV G
SCALE: 3:1	