

# MATERIALS & SPECIFICATIONS

PART NO.	A29000-185	REV	ECO	DATE	APP
		A	97798	07-27-11	TLM

- HOUSING:**  
ALUMINUM 6061-T6, NICKEL PLATE  
PER AMS-C-26074
- INSULATOR:**  
LIQUID CRYSTAL POLYMER (LCP) PER  
ASTM D5138
- CONTACT:**  
COPPER ALLOY PER MIL-DTL-32139,  
GOLD PLATED PER ASTM B488,  
(HARD GOLD) TYPE II CODE C CLASS  
1.27
- WIRE:**  
NEMA HP3 TYPE ET, COLOR CODED  
IAW MIL-STD-681, SYSTEM 1, USING  
TEN SOLID REPEATING COLORS
- HARDWARE:**  
303 STAINLESS STEEL PER ASTM 582
- CURRENT RATING:**  
1 AMP MAX PER MIL-DTL-32139
- CONTACT RESISTANCE:**  
71 MILLIOHM MAX (71mV DROP MAX)  
@ 1.0 AMPS PER MIL-DTL-32139
- PERFORMANCE:**  
PRODUCT FAMILY TESTED TO AND  
PASSED THE PERFORMANCE  
SPECIFICATIONS OF TABLE VIII OF  
MIL-DTL-32139

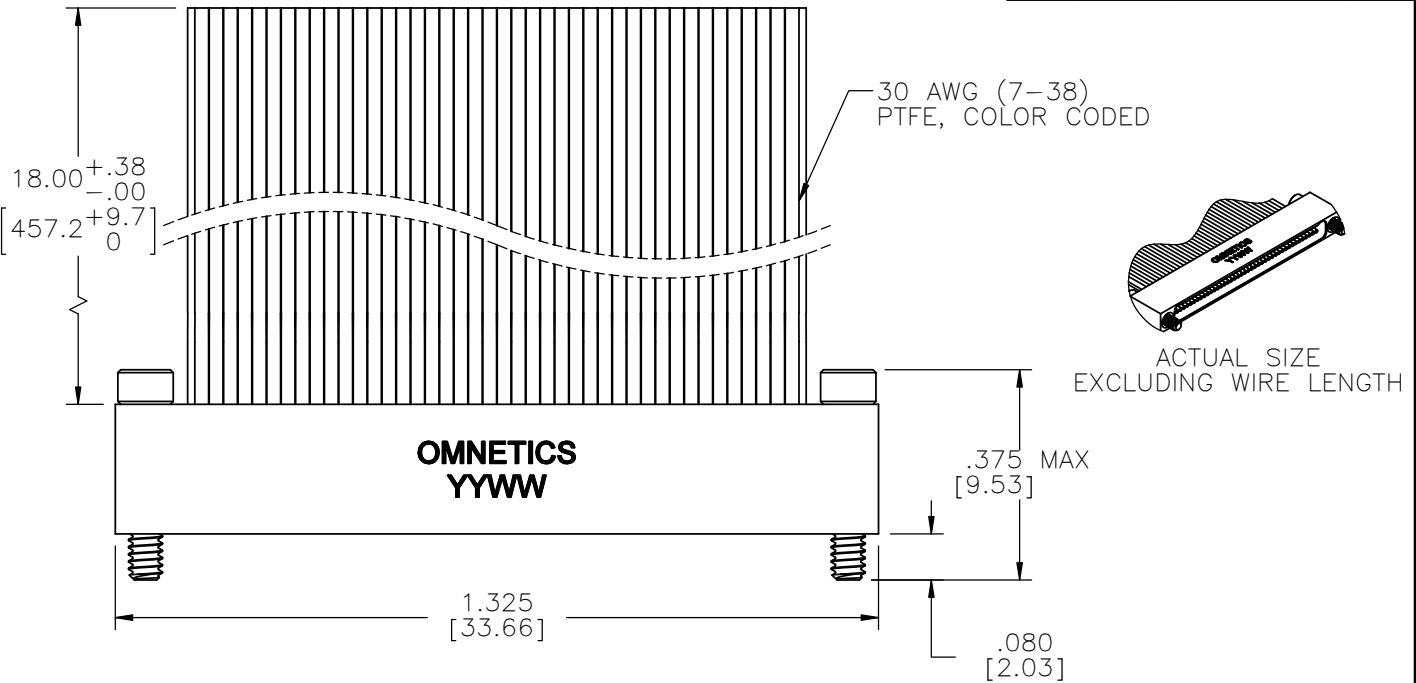

SOCKET #	COLOR
1, 11, 21, 31, 41, 51, 61, 71, 81	BLACK
2, 12, 22, 32, 42, 52, 62, 72, 82	BROWN
3, 13, 23, 33, 43, 53, 63, 73, 83	RED
4, 14, 24, 34, 44, 54, 64, 74, 84	ORANGE
5, 15, 25, 35, 45, 55, 65, 75, 85	YELLOW
6, 16, 26, 36, 46, 56, 66, 76	GREEN
7, 17, 27, 37, 47, 57, 67, 77	BLUE
8, 18, 28, 38, 48, 58, 68, 78	VIOLET
9, 19, 29, 39, 49, 59, 69, 79	GRAY
10, 20, 30, 40, 50, 60, 70, 80	WHITE

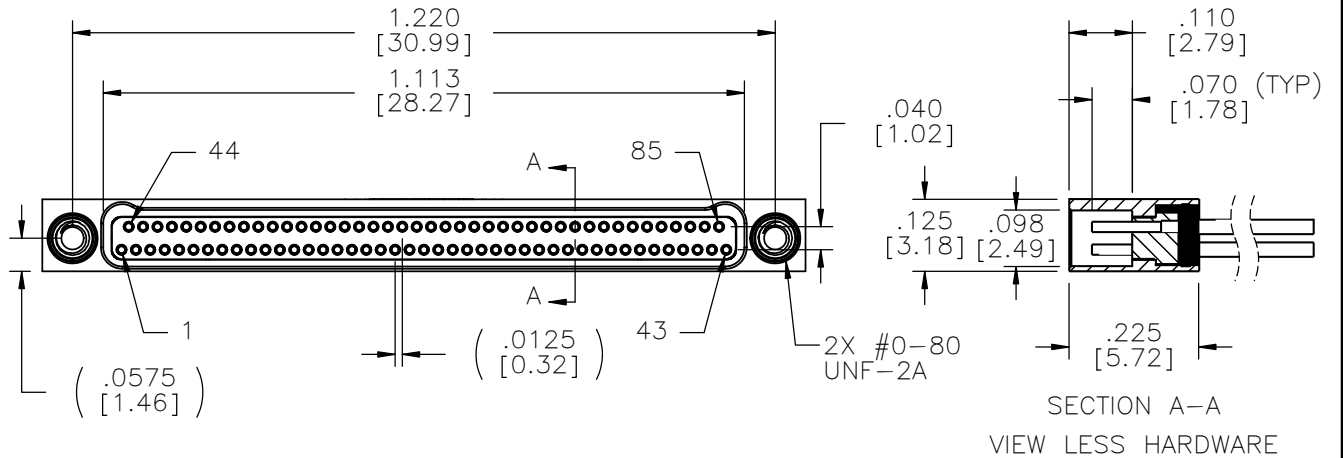

INTERNAL USE ONLY

SHEET 2 OF 2 IS A  
MFG LOADING DIAGRAM

MNSO SLDW	THIRD ANGLE
	-TOLERANCES-
	UNLESS OTHERWISE NOTED
	DIMENSIONS IN INCHES
	2 PL DEC ± .01
3 PL DEC ± .005	
4 PL DEC ± .0005	
ANGLES ± 1°	

THIS DRAWING CONTAINS CONFIDENTIAL AND PROPRIETARY INFORMATION WHICH IS THE PROPERTY OF OMNETICS CONNECTOR CORP. THIS DOCUMENT MAY NOT, IN WHOLE OR IN PART, BE DUPLICATED, OR DISCLOSED FOR ANY PURPOSE, WITHOUT WRITTEN PERMISSION FROM OMNETICS CONNECTOR CORP.

DFTM. DGJ	DATE	TITLE:
CHK'D.	DATE	(85) SOCKET FEMALE
APP'D.	DATE	BI-LOBE CONNECTOR

**OMNETICS**  
CONNECTOR CORPORATION

7260 COMMERCE CIRCLE EAST  
MINNEAPOLIS, MN 55432  
WWW.OMNETICS.COM

CAGE CODE	61873
DWG NO.	A29000-185
SHEET 1 OF 2	REV A
SCALE:	3:1