

# MATERIALS & SPECIFICATIONS

PART NO.	A28400-085	REV	ECO	DATE	APP
		D	102842	08-26-16	TLM

**HOUSING:**  
ALUMINUM 6061-T6, NICKEL PLATE PER  
SAE-AMS-2404

**INSULATOR:**  
LIQUID CRYSTAL POLYMER (LCP) PER ASTM  
D5138

**CONTACT:**  
BERYLLIUM COPPER PER ASTM B194,  
C17200, GOLD PLATED PER ASTM B488,  
(HARD GOLD) TYPE II CODE C, CLASS 1.27

**TERMINATION:**  
SOLDER COATED WITH SN63A PER  
J-STD-006 OR AMS-P-81728

**CURRENT RATING:**  
1 AMP MAX PER MIL-DTL-32139

**CONTACT RESISTANCE:**  
71 MILLIOHM MAX (71mV DROP MAX) @  
1.0 AMPS PER MIL-DTL-32139

**PERFORMANCE:**  
PRODUCT FAMILY TESTED TO AND PASSED  
THE PERFORMANCE SPECIFICATIONS OF  
TABLE VIII OF MIL-DTL-32139

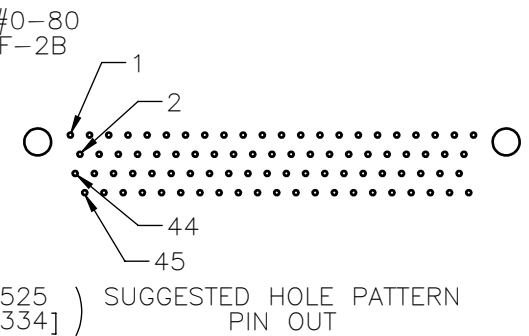
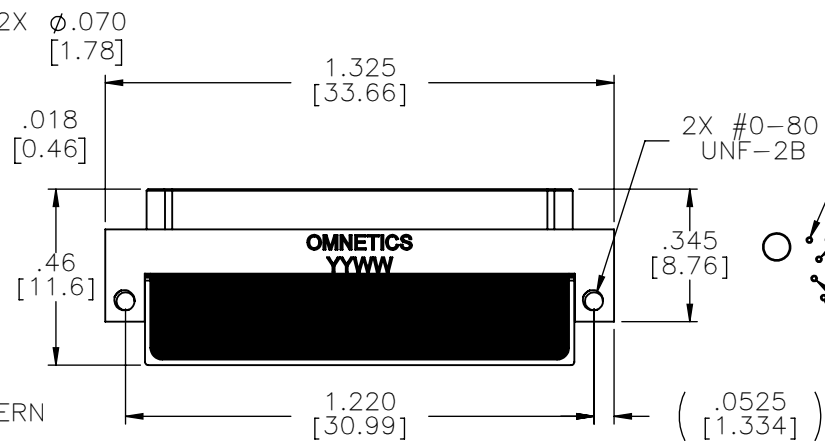
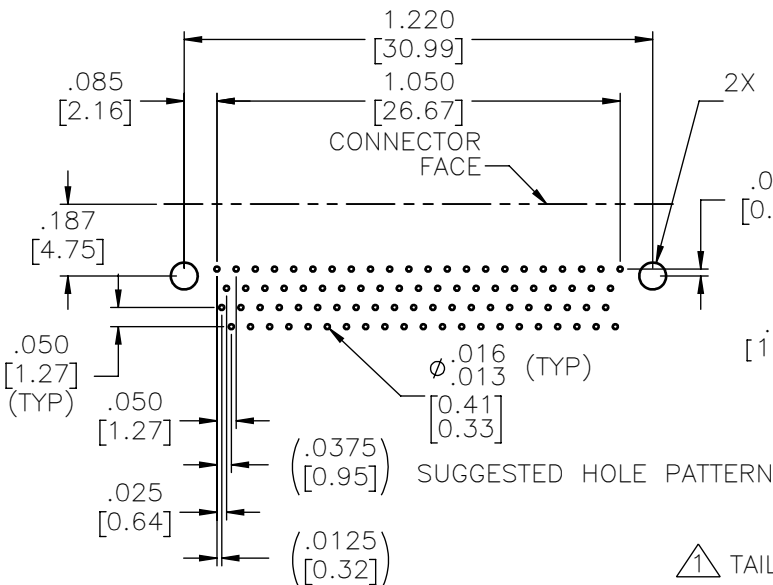
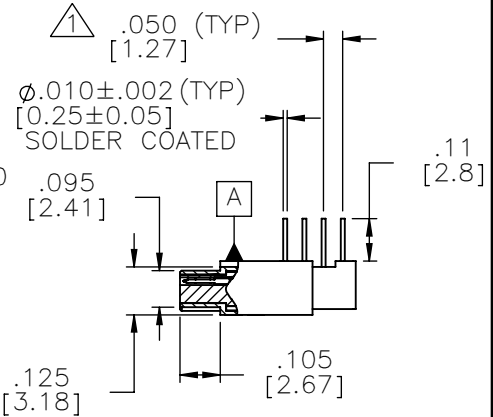
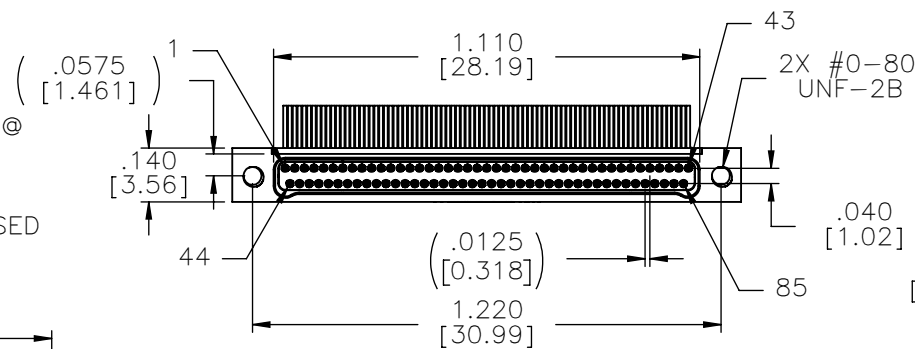
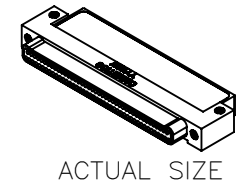
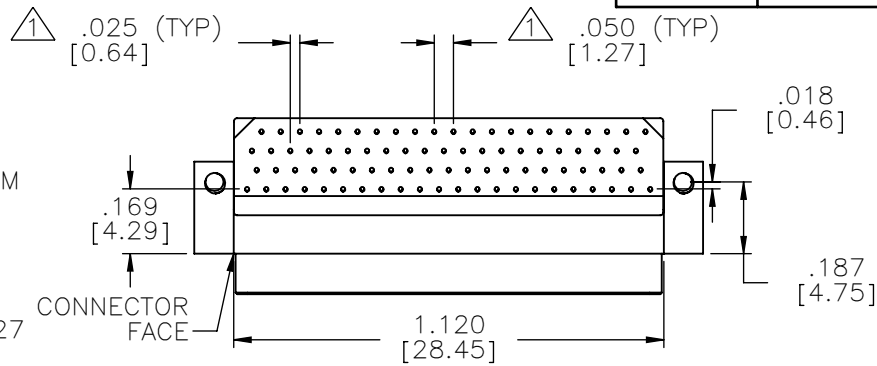

**TAIL DIMENSIONS APPLY AT PLANE A**

**NOTE:**  
DIMENSIONS IN [ ] ARE IN  
MILLIMETERS UNLESS  
OTHERWISE NOTED AND ARE  
FOR REFERENCE ONLY

MFG	THIRD ANGLE
	- TOLERANCES -
	UNLESS OTHERWISE NOTED
	DIMENSIONS IN INCHES
2	PL DEC ± .01
3	PL DEC ± .005
4	PL DEC ± .0005
	ANGLES ± 1°

THIS DRAWING CONTAINS CONFIDENTIAL AND PROPRIETARY INFORMATION WHICH IS THE PROPERTY OF OMNETICS CONNECTOR CORP. THIS DOCUMENT MAY NOT, IN WHOLE OR IN PART, BE DUPLICATED, OR DISCLOSED FOR ANY PURPOSE, WITHOUT WRITTEN PERMISSION FROM OMNETICS CONNECTOR CORP.	
DFTM. MJM	DATE 11-18-10
CHK'D.	DATE
APP'D.	DATE
TITLE: (85) PIN MALE Bi-Lobe® CONNECTOR	

**OMNETICS**  
CONNECTOR CORPORATION  
7260 COMMERCE CIRCLE EAST  
MINNEAPOLIS, MN 55432  
WWW.OMNETICS.COM

CAGE CODE 61873	
DWG NO. A28400-085	
SHEET 1 OF 1	REV D
SCALE: 2:1	